

CP-3

*Digital
Surround
Processor*

Unpacking and Inspection

After unpacking the CP-3, save all packing materials in case you ever need to ship the unit. Thoroughly inspect the CP-3 and packing materials for signs of damage. Remove the adhesive protective film from the CP-3 front-panel lens. Report any shipment damage to the carrier at once; report equipment malfunction to your dealer.

Precautions

This equipment has been tested and found to comply with the limits for a Class B digital device, pursuant to Part 15 of the FCC Rules. These limits are designed to provide reasonable protection against harmful interference in a residential installation. This equipment generates, uses and can radiate radio frequency energy and, if not installed and used in accordance with the instructions, may cause harmful interference to radio communications. However, there is no guarantee that interference will not occur in a particular installation. If this equipment does cause interference to radio or television reception, which can be determined by turning the equipment off and on, the user is encouraged to try to correct the interference by one or more of the following measures:

- Reorient or relocate the receiving antenna.
- Increase the separation between the equipment and the receiver.
- Connect the equipment into an outlet on a circuit different from that to which the receiver is connected.
- Consult the dealer or an experienced radio/TV technician for help.

This triangle, which appears on your component, alerts you to the presence of uninsulated, dangerous voltage inside the enclosure... voltage that may be sufficient to constitute a risk of shock.



This triangle, which appears on your component, alerts you to important operating and maintenance instructions in this accompanying literature.

WARNING:

TO REDUCE THE RISK OF FIRE OR ELECTRIC SHOCK, DO NOT EXPOSE THE UNIT TO RAIN OR MOISTURE.

WARNING:

DO NOT DEFEAT OR REMOVE GROUND PIN ON THE POWER PLUG.

Acknowledgements

The CP-3 is manufactured under license from Dolby Laboratories Licensing Corporation. Additionally licensed under one or more of the following patents: U.S. numbers 3,632,886, 3,746,792 and 3,959,590; Canadian numbers 1,004,603 and 1,037,877. "Dolby" and the double-D symbol are trademarks of Dolby Laboratories Licensing Corporation.

The CP-3 is manufactured under license from LucasArts Entertainment Company. "THX" and "Home THX Cinema" are trademarks of LucasArts Entertainment Company.

"Auto-Azimuth" and the A-Z logo

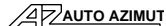

are trademarks of Lexicon, Inc.

Copyright ©1991 Lexicon, Inc.

All Rights Reserved.

Lexicon Patent: U.S. no. 4, 862, 502; other patents pending on the CP-3.

Lexicon, Inc. • 3 Oak Park Bedford, MA 01730 USA Tel 781-280-0300 Fax 781-280-0490

Safety Suggestions

Read Instructions Read all safety and operating instructions before operating the unit.

Retain Instructions Keep the safety and operating instructions for future reference.

Heed Warnings Adhere to all warnings on the unit and in the operating instructions.

Follow Instructions Follow operating and use instructions.

Heat Keep the unit away from heat sources such as radiators, heat registers, stoves, etc., including amplifiers which produce heat.

Ventilation Make sure that the location or position of the unit does not interfere with its proper ventilation. For example, the unit should not be situated on a bed, sofa, rug, or similar surface that may block the ventilation openings; or, placed in a cabinet which impedes the flow of air through the ventilation openings.

Wall or Ceiling Mounting Do not mount the unit to a wall or ceiling except as recommended by the manufacturer.

Power Sources Connect the unit only to a power supply of the type described in the operating instructions, or as marked on the unit.

Grounding or Polarization* Take precautions not to defeat the grounding or polarization of the unit's power cord.

*Not applicable in Canada.

Power Cord Protection Route power supply cords so that they are not likely to be walked on or pinched by items placed on or against them, paying particular attention to cords at plugs, convenience receptacles, and the point at which they exit from the unit.

Nonuse Periods Unplug the power cord of the unit from the outlet when the unit is to be left unused for a long period of time.

Water and Moisture Do not use the unit near water — for example, near a sink, in a wet basement, near a swimming pool, near an open window, etc.

Object and liquid entry Do not allow objects to fall or liquids to be spilled into the enclosure through openings.

Cleaning The unit should be cleaned only as recommended by the manufacturer.

Servicing Do not attempt any service beyond that described in the operating instructions. Refer all other service needs to qualified service personnel.

Damage requiring service The unit should be serviced by

qualified service personnel when:

the power supply cord or the plug has been damaged, objects have fallen, or liquid has been spilled into the unit,

the unit has been exposed to rain,

the unit does not appear to operate normally or exhibits a marked change in performance,

the unit has been dropped, or the enclosure damaged.

Outdoor Antenna Grounding If an outside antenna is connected to the receiver, be sure the antenna system is grounded so as to provide some protection against voltage surges and built-up static charges. Section 810 of the National Electrical Code, ANSI/NFPA No. 70-1984, provides information with respect to proper grounding of the mast and supporting structure, grounding of the lead-in wire to an antenna-discharge unit, size of grounding conductors, location of antenna-discharge unit, connection to grounding electrodes, and requirements for the grounding electrode. See figure below.

Power Lines An outside antenna should be located away

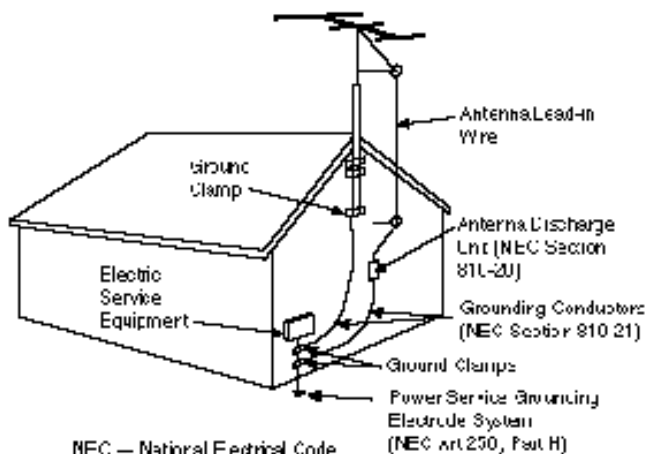

from power lines.

*CP-3
Digital Surround
Processor*

*Owner's
Manual*

Contents

1	Introduction to the CP-3	1
	Introduction	1
	Using the Documentation	3
	System Overview	4
2	Installation and Calibration	7
	Controls and Indicators	7
	The Front Panel • The Rear Panel	
	The Standard Remote • The Expanded Remote	
	Connection	12
	Location Considerations • AC Connections	
	Wiring Considerations • Audio/Video Connections • Connecting the CP-3 as a preamp • Connecting the CP-3 in a tape monitor loop • Video Connections	
	Calibration	18
	LCD Adjustment • The Video On-Screen Display • The Setup Menu	
	Setting the Speaker Configuration • Setting Input Levels • Setting Output Levels	
	Calibrating the Listener Position • Setting Rear Delay	
	Customization	30
	Locking in Settings • Custom Name	
	Custom Modes • Modifying the mode	
3	Using the CP-3	35
	Using the Modes	35
	Presets and User Registers	
	Panorama	36
	Ambience	38
	Reverb	40
	Surround	42
	Television • Music • Full Range • Mono Logic • Pro Logic • THX Cinema	
4	Troubleshooting	49
5	Installation Documentation	52
6	Specifications	57

Introduction

All of the operating modes of the Lexicon CP-3 Digital Surround Processor have a common goal: to draw you, the listener, more deeply into a musical performance or a film. For music the CP-3 uses true stereo digital processing to recreate the original recording space or to create a new one of your choosing. For films it offers an extremely accurate version of Dolby® Pro Logic Surround decoding with all of the enhancements of the LucasFilm Home THX® Cinema system and Lexicon's own decoding for monaural film soundtracks. The increase in impact of a musical performance or film when heard with the CP-3 is incredible.

A great deal of effort went into designing an instrument which would be flexible enough to satisfy the most critical listeners and yet be simple to operate. Essentially, the CP-3 is a signal processing computer that can be custom-programmed for any specific system. Once installed, it can be operated by either of the two remote controls supplied with the unit. The Standard Remote features simple, intuitive controls for most day-to-day operations; the Expanded Remote, which is used to customize the CP-3, allows complete control of every aspect of operation.

To recreate the experience of being at a live musical performance the CP-3 draws on recent studies of concert-hall acoustics, and applies this research to home listening rooms. Our auditory sense is quite adept at interpreting clues about our physical environment. Even with your eyes closed, it is possible to get a good mental picture of the room or hall you are in by listening to the ambience, or reflected sound energy, in the room. We are not aware of our auditory sense in everyday life because it confirms what our eyes identify as the environment. When we listen to recorded music, however, there are no visual clues and we rely completely on our sense of hearing. The introduction of two-speaker stereo systems over thirty years ago brought dramatic improvement to high fidelity music reproduction. With a carefully-designed system, and good recording, it became possible to produce a good sonic picture of the original event. Unfortunately, our listening rooms do not approximate the acoustics of a good concert hall, an intimate jazz club, or a magnificent cathedral — our ears tell us where we really are. The Lexicon CP-3 is designed to overcome this fundamental limitation to two-speaker reproduction and bring us closer to the ultimate goal of transporting ourselves to the original musical event.

The object is to increase the sideways-moving sound in a room, thus increasing Spatial Impression, or *SI*. The CP-3 increases *SI* by either extracting it from the original recording, using the Panorama or Surround modes, or by generating a new acoustic environment with Ambience or Reverb.

When a listener is in the correct spot the Panorama mode provides an almost ideal recreation of the original recording space. It works by using digital signal processing to cancel the crosstalk between the listener's ears, effectively spreading the sound from the two front loudspeakers in a wide arc in front of the listener. With the optional addition of rear speakers, Panorama can be startling in its realism.

The Ambience and Reverberation modes transform the listening room into a new acoustic space, letting you choose an environment which matches your music or your mood. Unlike most ambience processors, the CP-3 provides full stereo processing, preserving the critical SI information in the recording and expanding upon it. The Ambience mode generates the side and rear reflection patterns of idealized rooms and concert halls. The larger spaces add the true depth and realism of a concert hall to classical and popular music, while the smaller spaces are ideal for jazz and rock. The Reverberation mode is similar, but places more emphasis on rich, dense reverberant decay than on early reflections. It is especially good for simulating large, highly reverberant spaces such as churches, stadiums, and cathedrals.

The requirements for processing sound for home theater are quite different than those for music. Lexicon invented the technology that permits the most accurate reproduction of film sound in the same system that is used for music listening, and the software-based CP-3 is optimized for each of these unique tasks. The Music Surround mode is specifically designed to optimally play conventional stereo music through any system which includes side or side-located rear speakers. Additionally, the CP-3 is able to perform automatic analysis and error correction to compensate for problems in the source material.

For films encoded with Dolby Surround, Lexicon has incorporated the Lucasfilm Home THX Cinema processing into the CP-3. This utilizes a patented, completely digital Dolby Pro Logic Surround decoder, and is the only one with automatic correction of inter-channel phase and channel-balance errors (the most common audio problems in currently available video releases of films).

The CP-3 also provides modes for expanding monaural film sound tracks (Mono Logic), general TV viewing (Television) and, of course, direct two-channel stereo playback (Effects Mute ON).

Using the Documentation

Because the CP-3 is designed to be customized for your system and your listening space, the information required for installation is considerably more extensive than that required for use of the system. We have, therefore, provided separate documentation for these needs. The CP-3 is shipped with an Owner's Manual, a Quick Reference Card and a booklet titled: CP-3 Theory and Design.

The Owner's Manual is designed to assist you in installing, calibrating and operating the CP-3. It should be used in conjunction with the Expanded Remote Control when configuring the system to perform optimally in your environment. This manual was written with the underlying assumption that the installer is familiar with audio/video system installation.

To keep operation simple, the unit recognizes which remote control is used to turn it on. In the Owner's Manual, references to "Standard" operation mean that the unit was turned on with the Standard remote; "Expanded" operation refers to the Expanded remote. "Normal" operation refers to modes for *using* (as opposed to *setting up*) the CP-3.

An Installation worksheet is provided in Chapter 5 of the Owner's Manual for documentation of the settings arrived at during the calibration procedure.

Once installation is satisfactorily completed, you should need only the Standard Remote and the Quick Reference Card for day-to-day operation of the system.

Whether you are performing the installation, or simply using the system, we hope that you will read the Theory and Design booklet. Understanding the goals of CP-3 design will make sense of each step in the setup procedure, and will help you make the most of the operating features.

System Overview

Although the CP-3 performs very complex signal processing, a great deal of effort has gone into making the technology behind the effects as transparent as possible to the user. To understand the overall organization of the unit, it is helpful to define those few terms which are unique to the CP-3.

Glossary of Terms

Mode A *mode* is a configuration that determines how the CP-3 will process an input signal. The CP-3 contains four basic modes: Panorama, Ambience, Reverb and Surround. Each of these basic modes has a set of variations which are labeled on the Expanded remote (1-15). In this manual, these 15 variations are also referred to as modes.

Parameter Each mode has a set of *parameters* (controls) that uniquely characterize it. The settings of the parameters can be changed to create custom *User modes*.

Mode Parameter values are stored/recalled in Presets and User modes. Some examples are: Delay Time, Bass Split, etc.

System parameter values are not associated with a particular mode. System parameters are not stored in User registers or Presets, nor do their values change when a new mode is recalled. Examples are: display contrast, volume, etc.

Register The CP-3 contains 45 *registers*, or memory locations, where modes are stored.

Bank The CP-3's 45 registers are organized into 3 *banks*, of 15.

Presets One bank of 15 registers is loaded with the modes which appear on the Expanded Remote. These modes are *presets* which are permanently initialized at the factory. Presets appear on the display with their names and their numbers preceded by the letter P.

User Registers Two banks of 15 registers each are designated as *User registers*. These are available for storing your own custom modes. The factory presets cannot be overwritten, but they can be modified and stored into User registers (or copied into registers, then modified). When shipped, the CP-3 has a duplicate of the presets loaded into both Bank A and Bank B. The contents of User registers appear on the display with their names and their numbers preceded by the Letter A or B.

Finding your way around

Press SETUP to display the Setup menu. PARAM will step a cursor through the Setup menu selections. Once an item is selected, pressing PARAM ▲ or ▼ will display a sub-menu for that item. With the sub-menu displayed, PARAM once again selects menu items. PARAM ▲ and ▼ adjust the settings of the selected item over its available range. Press STORE to exit any sub-menu; press SETUP to return to the Setup menu. Press SETUP again to exit the Setup menu.

Essentially, the CP-3 can be thought of as a line level preamp with one audio-only and three audio/video inputs. It behaves as the master processor for your system, controlling system volume, balance, source selections and acoustical environments.

Two remote control units are provided with the system: an Expanded remote, and a Standard remote. The Expanded remote is designed primarily for use in configuring the CP-3 to work optimally with your system. This remote gives you access to setup controls and parameter menus for all of the modes of operation of the CP-3. This remote also allows access to 15 Preset modes and storage of as many as 30 of your own custom modes.

Although some users may continue to use the Expanded remote after installation and configuration is complete, a second, simpler remote control, called the Standard remote, is provided for everyday use. This remote is designed to control some system parameters and to access only five modes of operation. (We have chosen names for these modes, as labeled on the Standard remote, but the actual modes that are triggered by these buttons can be changed.)

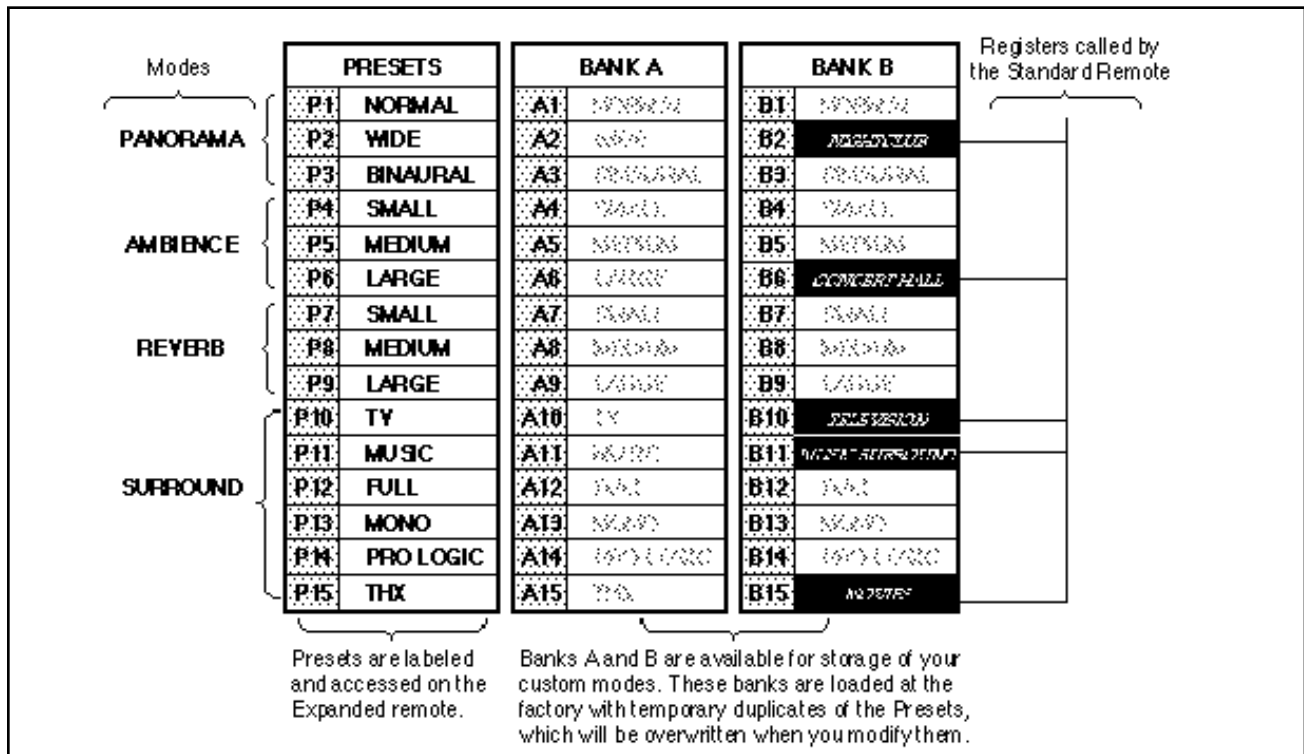

In many systems, a universal, or learning remote, may take the place of the Standard remote. If you are using one of these, we strongly suggest that the types of operating controls we have provided on the Standard remote be adapted into the universal remote. We have found these controls enhance the listening/viewing experience while keeping the technology transparent.

Controls and Indicators

The Front Panel

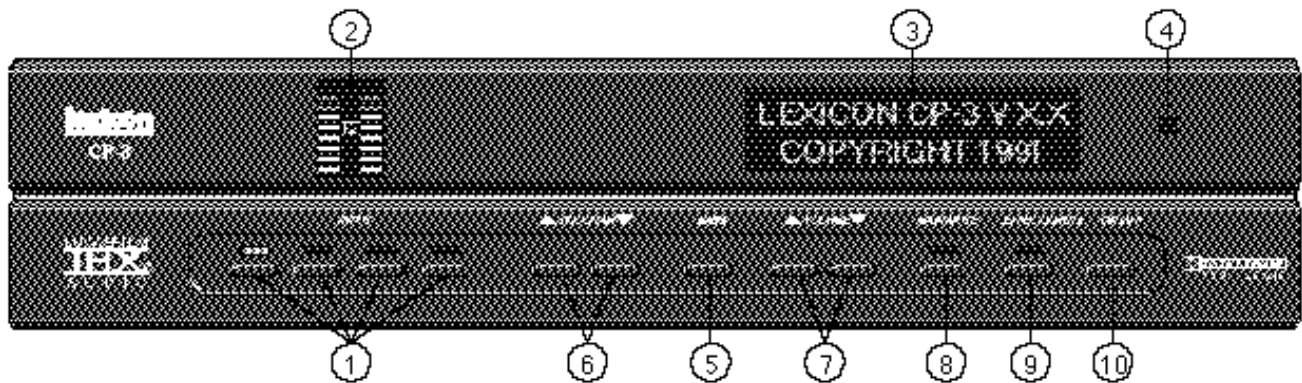

1. Input

The four INPUT buttons are used to select which input is processed by the CP-3. Pressing any one of these buttons will select that input and light the LED above it. The CP-3 can be programmed to engage a specific operating mode for each input, so changing inputs may change the mode being used. See Auto-Mode Load, Page 24.

2. Input Level Display

The INPUT LEVEL display monitors the level in the CP-3's digital encoding circuits and is used to indicate the correct Dolby level for video sound sources (marked by the double-D symbol between the LEDs.) When correctly set, the loudest passages will light the entire row of green LEDs, the two yellow ones, and occasionally flash the red peak LEDs at the top. See Page 22, Setting Input Levels. (The input level meters can be turned off to eliminate distraction — See Page 19.)

3. Alphanumeric Display

The alphanumeric LCD (liquid crystal display) shows both the mode that is running and its modifiable parameters. The contrast of the LCD can be adjusted for optimum visibility. See Page 18. (A video on-screen display is described on Page 19.)

4. Infrared Receiver

The small unlabeled window to the right of the LCD houses the infrared receiver used by the CP-3 to detect signals from the remote controls.

5. Bank

In Expanded operation, the BANK button cycles through the Preset bank and two User banks (A&B) where customized modes can be stored. The mode number doesn't change: if you are using Preset 9, pressing BANK once switches to User A9, pressing it again switches to User B9, pressing it again switches back to Preset 9. In Standard operation, the BANK button is inoperative.

6. Program

The PROGRAM button steps through the modes of the bank currently in use. Using its Expanded modes, the CP-3 can have as many as 45 operating modes: Presets 1-15 are configured at the factory, those labeled User A1-15 and User B1-15 are available for storage of modes customized by the user.

In Standard operation, 5 modes are available.

7. Volume

The VOLUME buttons adjust the level of all channels simultaneously. These buttons assume the function of the volume control on your preamp or receiver.

8. Main Mute

MAIN MUTE turns off all outputs and lights both MAIN and EFFECTS MUTE LEDs.

9. Effects Mute

EFFECTS MUTE turns off all signals added by the CP-3, lights the yellow EFFECTS MUTE LED on the front panel, and displays "EFFECTS MUTED." This bypasses all signal processing in the CP-3 except level control, and is the simplest way to play "normal" two-speaker stereo. Pressing again will restore normal operation.

10. On/Off

ON/OFF alternately puts the CP-3 into and out of standby mode. Turning the CP-3 off with this button (or with either remote) deactivates the unit while leaving power to the signal processing circuitry to keep it at optimum operating temperature. Although this switch may be used to turn the CP-3 off, it is important that the CP-3 be turned on with the remote control that will be used during each listening session. If the front panel switch is used to turn on the CP-3, it will resume operation in whichever mode (Standard or Expanded) it was last in.

The Rear Panel

CAUTION: Never make or break any connections to the CP-3 with the rear-panel power ON. Make sure any associated amplifiers have been turned off for at least one minute before turning this master power switch on or off.

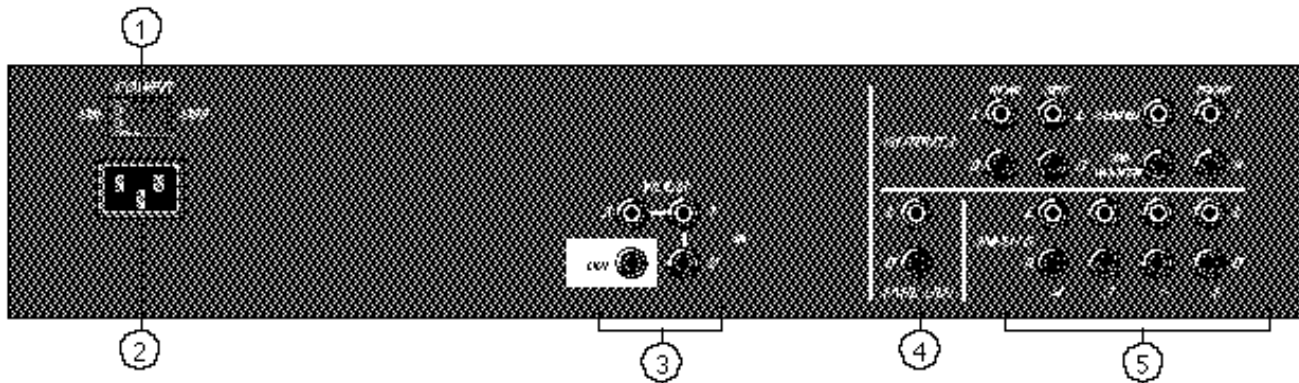

1. Power On/Off

The master power switch should be left ON when the unit is in regular use. When the CP-3 will not be used for an extended period of time, or whenever you are connecting or disconnecting any cables to the unit, this switch should be turned OFF.

2. Power Connector

Connect the supplied AC power cord here, then plug the cord into an unswitched outlet. Be sure that the power cord is firmly seated in this connector.

3. Video In and Video Out

The three video inputs are switched with their corresponding audio inputs and fed to VIDEO OUT. VIDEO OUT should be connected to a video input on your monitor for the On Screen display to work. The CP-3 will generate a blue background field if there is no video signal in the selected input. If the CP-3 is turned off via the front panel or either remote, the last input selected will continue to be passed to the video output. If the rear-panel master power switch is turned off, or if AC power is removed from the unit, the video output will default to Input 1.

4. Tape Out

This provides an unprocessed, buffered audio output of whatever input has been selected. This output will be active if the CP-3 is turned off via remote, or front panel, but is shut off when the rear-panel master power switch is turned off.

5. Audio Inputs and

Outputs

There are four stereo audio inputs on the CP-3. Input 4 is audio only; it uses the video signal from Video Input 1.

Stereo outputs are provided for Front, Side, and Rear amplifiers, as well as single monaural outputs for the Center speaker amplifier and the Subwoofer amp.

The Standard Remote

1. The Operating Modes

The five operating mode buttons on the Standard Remote can be customized to load any of 45 operating modes. The specific modes we recommend for each button are:

NIGHTCLUB gives the best re-creation of the original recording venue, but covers a somewhat limited listening area. This mode is most suitable for intimate listening of any type of music.

CONCERT HALL creates the sound of a near-perfect large concert hall with your seat in the front third. This mode covers a very large listening area, and is best for large-scale works.

MUSIC SURROUND is a unique, versatile surround program that adapts itself to the individual recording. The results, which can be quite subtle on simply miked recordings, are spectacular on heavily produced recordings.

TELEVISION provides surround effects for television viewing of monaural, stereo, and stereo synthesized programs.

MOVIES (Home THX Cinema) is designed for any surround sound encoded movies, music, or television programs.

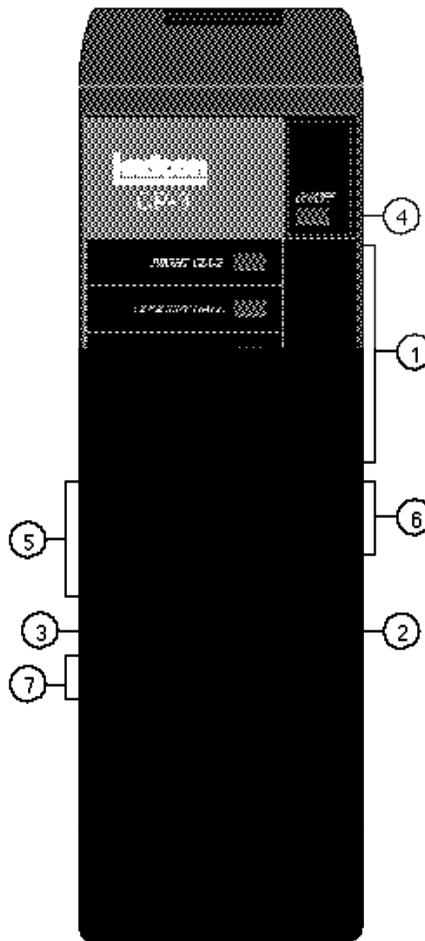

2. Main Mute

Turns off all outputs, lights both MAIN and EFX MUTE LEDs and displays "SYSTEM MUTED." Pressing again will restore normal operation. (Because it is possible to alter the setting of the volume while Main Mute is on, check the volume before you turn the mute off again.)

3. EFX Mute (Effects Mute)

Turns off all signals added by the CP-3, lights the yellow EFFECTS MUTE LED on the front panel, and displays "EFFECTS MUTED." This bypasses all signal processing in the CP-3 except level control, and is the simplest way to play "normal" two-speaker stereo. Pressing again will restore normal operation.

Pressing EFX MUTE after the MAIN MUTE (which mutes the main and effect outputs) has been engaged will turn the effect mute off while leaving the main speakers muted. This allows you to hear the effect the CP-3 is adding without the main channels on. Operation depends on the mode in use and is explained in the manual section for each mode.

4. On/Off

Turning the CP-3 off with this button (or the front panel ON/OFF button) deactivates the unit while leaving power to the signal processing circuitry to keep it at optimum operating temperature.

The CP-3 uses this button's signal to differentiate between the remotes. Therefore it is important that the CP-3 be turned on with the remote control that will be used during each listening session. To use the other remote, simply turn the CP-3 off (with either remote or the front panel switch), then turn it on with the ON/OFF button of the remote you wish to use.

5. Balance

These four buttons adjust the level of the sound relative to the other channels. For instance, pressing the left arrow will turn down the level of all the right channels. The effect of the Front/Back control on the side channels will depend on speaker configuration and operating mode.

6. Volume

These buttons simultaneously adjust the level of all channels. It should be used instead of the volume control on your preamp or receiver.

The first push of either of these buttons displays the current value for 2 seconds; another push during that time increases or decreases the displayed value. Holding the button down for 1 second engages auto-repeat, changing the value rapidly.

7. Input

Buttons 1-4 select the input source and can be programmed to automatically engage the desired operating mode.

The Expanded Remote

1. The Modes

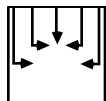

The PANORAMA modes (1, 2 and 3) provide enhanced lateral sound (and hence greater spaciousness and envelopment) for either music or films. This mode is effective even using only the two front loudspeakers. NORMAL(1) and WIDE(2) differ primarily in their initial Effect Levels. BINAURAL(3) is for playback on loudspeakers of recordings made with a dummy head microphone system.

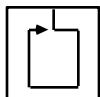

The AMBIENCE modes (4, 5 and 6) simulate concert halls of three different sizes, generating reflections of appropriate directionality, delay and spectral shape, sending them to the side and rear speakers. The Ambience modes provide adjustable recirculation through the Liveness parameter but for long reverberation times, use Reverb. Both Ambience and Reverb are true stereo simulators.



Like Ambience, the REVERB modes (7, 8 and 9) simulate rooms of three sizes with the aid of side and rear channels. These modes have fewer specific initial reflections than Ambience, but richer and smoother reverberant decay. Reverb is especially good for simulating large, highly reverberant spaces.

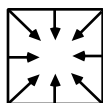

SURROUND: TV (10) is designed to expand and enhance a wide range of television programming. This mode also allows adjustment of certain parameters for film sound which are not adjustable in Mode 14. If a program is designated as being in surround, use Pro Logic (14), or THX (15).

MUSIC (11) enhances music through a unique ambience extraction method, and can provide spectacular results with music that has carefully recorded stereo information.

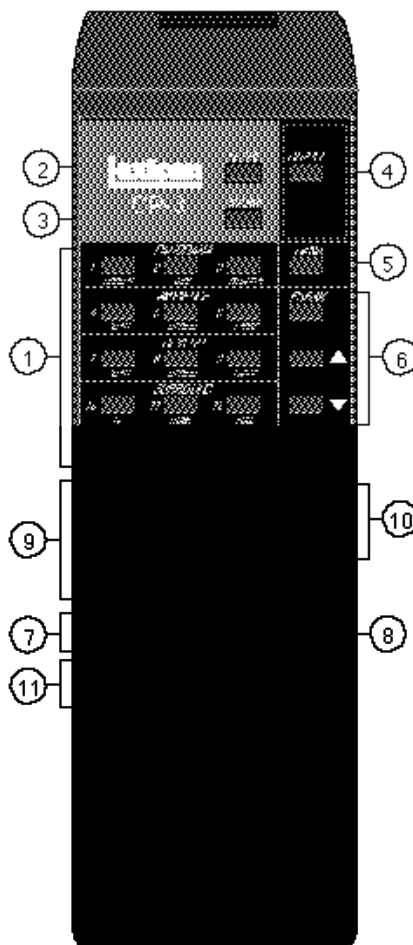

THX CINEMA (15) combines Dolby Pro Logic decoding and the spectral enhancements of the LucasFilm Home THX Cinema system to re-create film sound in your home the way it was heard in the final production stages.

2. Setup

The SETUP button allows selection and adjustment of all the interface functions of the CP-3 including Input and Output levels, visual displays, speaker configurations, etc.

3. Store

The STORE button saves in memory the settings from the SETUP mode and is used to memorize and store any customized operating modes.

4. On/Off

Turning the CP-3 off with this button (or the front panel ON/OFF button) deactivates the unit while leaving power to the signal processing circuitry to keep it at optimum operating temperature.

The CP-3 uses this button's signal to differentiate between the remotes. Therefore it is important that the CP-3 be turned on with the remote control that will be used during each listening session. To use the other remote, simply turn the CP-3 off (with either remote or the front panel switch), then turn it on with the ON/OFF button of the remote you wish to use.

FULL (12) allows unprocessed music to be played over all the speakers for background music, or for maximum acoustical output of the system.

MONO (13) expands the music and effects on monaural films into the additional channels while leaving the dialog in the front center.

PRO LOGIC (14) provides the same decoding used in Dolby Stereo theater systems, using as many as eight speakers for front, center, side, rear, and subwoofer channels.

5. Bank

The BANK button switches between the three register banks: the Presets and the two User register Banks (A & B) where customized modes may be stored. The mode number doesn't change: if you are using Preset 9, pressing BANK once switches to User A9, pressing BANK again switches to USER B9, and pressing BANK once more selects Preset 9.

6. Parameter

The three parameter buttons allow selection and adjustment of variable parameters within each mode. Pushing PARAM displays the parameter menu with a moveable cursor for 5 seconds; pushing it again before the display changes moves the cursor to the next parameter. Pressing PARAM ▲ or ▼ will display and adjust the current parameter (whether or not PARAM has been pushed.) A single push of either of these buttons displays the parameter; another push changes the parameter by one unit. Holding PARAM ▲ or ▼ for more than 1 second causes the values to change rapidly in an *auto-repeat* mode.

7. Effects*

▲ and ▼ adjust the level of all signals added by the CP-3.

8. Mutes

MAIN MUTE turns off all outputs and lights both MAIN and EFX MUTE LEDs. Pushing EFX MUTE while in system-mute mode turns the effects alone back on. EFX MUTE alternately turns off and on all signals added by the CP-3. Use it to compare the sound with and without CP-3 processing, or as a simple way to play normal two-speaker stereo.

9. Balance*

BALANCE: The four balance buttons adjust the levels of the rear speakers relative to the sides and fronts, and the left/right balance of all speakers: front, sides and rear. It should be used instead of the balance control on your preamp or receiver.

10. Volume*

▲ and ▼ simultaneously adjust the level of all channels. These should be used instead of the volume control on your preamp or receiver.

11. Input

INPUT buttons 1-4 select the input source and can be programmed to automatically engage the desired operating mode.

**The first push of either of these buttons displays the current value for 2 seconds; another push during that time increases or decreases the displayed value. Holding the button down for 1 second engages auto-repeat, changing values rapidly.*

Note: Unless otherwise indicated, all references to the remote control in this manual refer to the *Expanded Remote*.

Connection

Location Considerations

The CP-3 is a highly specialized signal processing computer and requires special care during installation to ensure optimum performance.

The CP-3 may be installed on a shelf or in a standard 19" equipment rack, using rack-mounting hardware available from Lexicon. Observe the following precautions:

- Select a dry, well-ventilated location out of direct sunlight.
- Do not stack the CP-3 directly above heat-producing equipment such as power amplifiers.
- Avoid placing the CP-3 near unshielded TV or FM antennas, cable TV decoders, or other receivers. The CP-3 may interfere with some FM tuners if it is placed immediately above or below them. Some products, particularly power amplifiers, may cause hum in the CP-3 if they are in close proximity.
- Make sure the IR receiver window (located above the On/Off switch on the CP-3 front panel) is unobstructed. The remote control must be in line-of-sight to this receiver for proper operation. If line-of-sight is impractical, an infrared remote repeater can be used. Place the sender/emitter so that it has an unobstructed path to the CP-3's IR receiver window. The CP-3 may be placed in a glass-doored cabinet but smoked glass will make the front panel Liquid Crystal Display (LCD) difficult to read and will reduce the sensitivity of the IR receiver.
- Do not mount the CP-3 into walls or ceiling.

AC Connections

The CP-3 is designed to be connected to an uninterrupted AC power line in the same manner as a VCR or aTV with a clock in it. Like all computers, the CP-3 is sensitive to voltage fluctuations. We therefore recommend the use of an AC line filter to protect against line surges, or the installation of a line conditioner to protect against under voltage (brownouts) as well as over-voltage conditions. A lithium battery prevents loss of information stored in the CP-3 in the event of power loss. This battery should not need replacement for 5-7 years. As it is not user-replaceable, please contact Lexicon or your local dealer for service.

The CP-3 has a master power switch on the rear panel above the IEC standard AC power receptacle. This switch may be left ON continuously when the unit is in regular use. When the CP-3 will not be used for an extended period of time, or whenever you are connecting or disconnecting any cables to the unit, this switch should be turned OFF.

Connect the power cable to the CP-3, then plug the power cord into a wall outlet or into an unswitched outlet on the back of your preamplifier. Be sure that the power cord is firmly seated in the connector on the rear panel of the CP-3.

Wiring Considerations

Audio/Video Cables

There is controversy over the audible effects of different types of interconnects. Good engineering practices have minimized the effect that cables might have on the inputs and outputs of the CP-3 — but feel free to evaluate different interconnects in your system. If you want to do some tweaking, be conscious of the mechanical stress from repeated insertion and overly tight connectors, and the possibly corrosive nature of some contact-enhancing fluids.

Note that the use of audio cables for video applications may cause signal degradation, and is not recommended. For video connections, please use only cables that are designed for video applications — these have different impedance characteristics than cables approved for audio applications.

Both audio and video cables should be kept as short as possible.

In general, speaker cables should be kept short, and low-impedance wire should be used throughout to assure efficient power transmission and avoid audible distortion. Recommended wire lengths are given in the table below. Although these examples can be used as a general guide, your system manuals should provide detailed information specific to your components.

Speaker Connections

Wire Lengths	
Length	AWG Size & Stranding
up to 12 feet	16 gauge (19/29)
up to 18 feet	14 gauge (19/27)
up to 29 feet	12 gauge (19/27)
up to 51feet	10 gauge (105/30)

Contact your dealer for specific recommendations regarding interconnects and speaker cables.

Audio/Video Connections

Before making any connections, turn off ALL audio and video components, including individual power amplifiers. (Unplug any preamps and power amps that don't have power switches.)

The CP-3 is designed to function as the control center of the system, selecting inputs and controlling the volume of all speakers in the system. There are several ways to integrate the CP-3 into the system, but they basically fall into two categories: those where the CP-3 is connected directly to all of the amplifiers in the room, and those where the CP-3 is connected into a tape or signal processor loop of a preamp or receiver.

As most systems which use the CP-3 are likely to be fairly complex, one of the design goals should be to make the entire system intuitive to use. If there are no more than four line level (not a turntable) sources, it is easiest to hook them directly to the inputs of the CP-3, and to connect all of the system amplifiers to the CP-3 outputs. If a mono source is used (such as an older VCR), a Y-connector should be used to connect to both left and right audio inputs on the CP-3.

Many installations will have more than four sources in the system. A preamp, or A/V switcher, can handle the additional components — and possibly add some additional dubbing capabilities. A preamp has the advantage of a built-in phono amp, and many include decent tone controls as well. The disadvantages include: a redundant gain stage, another volume control that can be set incorrectly, forfeit of remote switching and loss of the CP-3 programmable input functions for the sources connected through the preamp. An A/V Switcher may yield more dubbing flexibility, and should be considered if there is no turntable in the system.

You may choose to connect the CP-3 in the tape monitor, or external processor loop of a preamp, allowing you to completely bypass the CP-3. This, however, will make the system somewhat more complicated to operate, and adds a gain stage (the preamp) that is not needed.

CAUTION: The CP-3 Tape Out output is *not* a tape monitor circuit. The audio input selected is always fed directly to Tape Out. If a tape deck is connected to this output and one of the inputs, and that input is selected, a feedback loop will result. This can damage the amplifiers, the speakers, and your ears.

If there are four or fewer sources to be used in the system, they can each be connected directly to the CP-3 inputs. A typical system might use Input 1 for television, Input 2 for VCR, Input 3 for video disc and Input 4 for CD player or turntable (output through a preamp). Since Input 4 is audio only, the video output will default to the video signal from Input 1. This feature allows TV or other video source viewing while different audio is playing.

Connecting the CP-3 as a preamp

Connect your main stereo amplifier to the CP-3's FRONT outputs. Connect any additional amplifier/speaker combinations to the remaining outputs on the CP-3: side amplifiers to the SIDE outputs, rear amplifiers to the REAR outputs, center-channel amplifier to the CENTER output and the subwoofer amp to the SUB WOOFER output. If you are using THX-type dipolar surround speakers, the amplifier driving them should be connected to the CP-3 SIDE outputs.

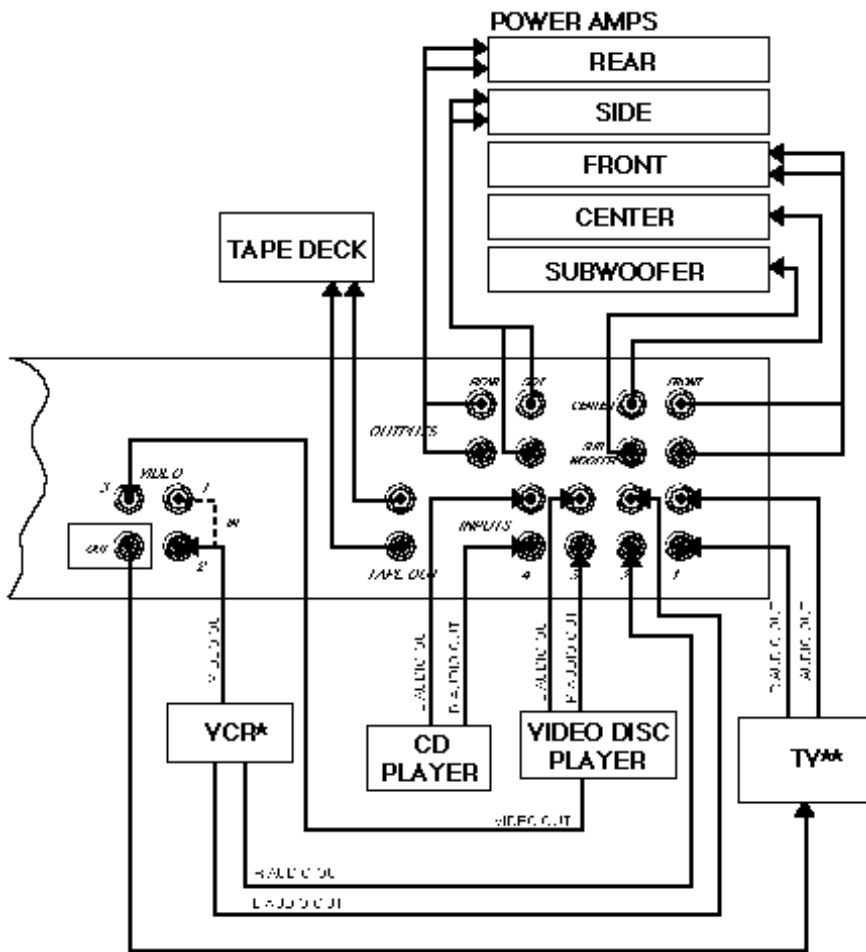

* In this configuration, use a Y-connector to hook the VCR to Video 1 as well if its tuner is used instead of the TV tuner.

** In this configuration, select the TV's video input to see the CP-3's on-screen display.

Connecting the CP-3 in a Tape Monitor Loop

If you have a receiver with no external access to the preamplifier outputs, you can use a tape output or external processor loop to the CP-3. However, any change in the receiver's volume control after the system is adjusted will upset the balance between the main and auxiliary speakers.

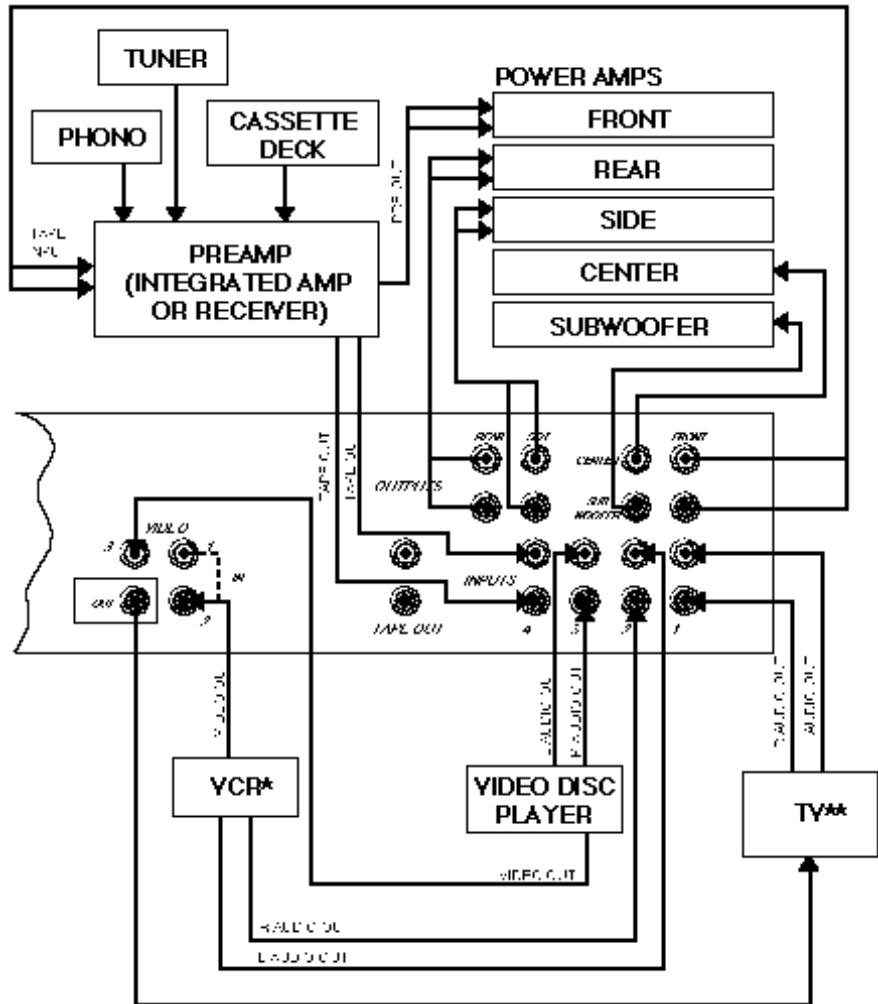

* In this configuration, use a Y-connector to hook the VCR to Video 1 as well if its tuner is used instead of the TV tuner.

** In this configuration, select the TV's video input to see the CP-3's on-screen display.

The CP-3 has three video inputs and one video output. The inputs are labeled VIDEO IN 1, 2, and 3, and are switched along with audio inputs 1, 2, and 3 via the front panel or either remote. (Audio Input 4 will use the video signal from Video Input 1.) These inputs are designed for standard NTSC composite video signals such as those found at the outputs of video disc players and VCRs.

Video Connections

If the CP-3 is turned off via remote or front panel, the last selected video input will continue to be fed to the output (the audio will be muted), so the CP-3 need not be left on, for example, for simple TV viewing. If the master power switch on the CP-3 rear panel is turned off, or if power is removed from the CP-3, the unit will default to Input 1 for audio and video, and will continue to pass that signal through to the output.

NOTE: The CP-3 video inputs are designed for NTSC "M" composite video signals. The video circuitry is capable of overlaying text on the incoming video signal; it is also capable of generating its own blue text background in the absence of an incoming video signal. Even though the video circuitry is designed for NTSC only, it can synchronize to incoming PAL and SECAM composite video signals and overlay text on the picture. In doing this, however, the text will lose sharpness, especially in SECAM.

Calibration

When turning on the CP-3 for the first time, perform the Restore Defaults routine described in Chapter 4 of this manual.

LCD Adjustment

Depending on the location of the CP-3 in your room, you may need to adjust the front panel Liquid Crystal Display (LCD) for optimum viewing.

To adjust this display, press the SETUP key on the Expanded Remote. The CP-3 is now in SETUP mode. Within this mode, operations are carried out using the three PARAM buttons and STORE.

The LCD will now read:



Press PARAM to step to the DISPLAY ADJUST menu, then press PARAM ▲. The LCD will now read:



Pressing PARAM twice will step to the following display:



Pressing PARAM ▲ or ▼ will display:



Press PARAM ▲ or ▼ until the contrast of the display is at a maximum as seen from your listening chair.

Press SETUP to return to the main menu.

In addition to the front-panel LCD, the CP-3 contains a character generator for a video overlay display on television sets. Since the On-Screen Display is capable of showing the full menu of options available at any point, calibration of the system is faster and easier if the CP-3 video output is connected to a video input on a television monitor.

The Video On-Screen Display

Adjustments to the on-screen display are made from the Display Adjust menu. To display this menu, press SETUP. The display will show the options available in the Setup menu. Press PARAM to move the cursor to "DISPLAY ADJUST", then press either PARAM ▲ or PARAM ▼ to display the Display Adjust menu.

This menu allows you to choose both the position and duration of items displayed on-screen during normal operation.

Adjusting the position allows you to move the CP-3 display items to a location where they will not interfere with any other video overlays your system may generate.

The "DISPLAY TIME" option allows you to choose to have the on-screen display always off, always on, or on for a two-second duration. Note that if you choose to have the display "time out", this will not affect the display of the Setup menu. Note also that parameter changes will still be effected when you make adjustments with PARAM ▲ or ▼, even if the display is inactive.

If you choose "Always Off", you will not be able to use the video overlay, and even setup will have to be done using only the front-panel LCD.



Move cursor with PARAM then press PARAM ▲ or ▼ to select	DISPLAY ADJUST	Adjust with PARAM ▲ or ▼
	OSD POSITION	Bottom, Center, Top
	DISPLAY TIME	Always Off, 2 sec, 1 minute, Always On
	LOGO CONTRAST	continuously adjustable
	LEVEL METERS	ON or OFF

Once installation and calibration procedures are completed, if you find the input level meters visually distracting, you can turn them off from the Display Adjust menu. Simply press PARAM to select "LEVEL METERS" at the end of this menu, then press PARAM ▼ twice to select OFF.

Press SETUP to return to the main menu.

The Setup Menu

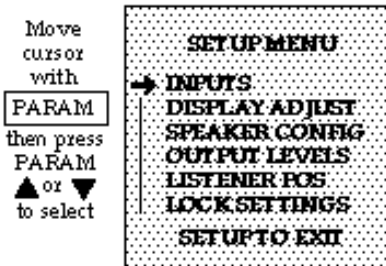

Press SETUP to display the Setup menu. PARAM will step the cursor through the Setup menu selections. Once an item is selected, pressing PARAM ▲ or ▼ will display a sub-menu for that item. With the sub-menu displayed, PARAM once again selects menu items. PARAM ▲ and ▼ adjust the settings of the selected item over its available range. Press STORE to exit any sub-menu; press SETUP to return to the Setup menu. Press SETUP again to exit the Setup menu. For your reference, all of the options available in the Setup menu are shown here.

Move cursor with
PARAM then press PARAM ▲ or ▼ to select

INPUT MENU	Adjust with PARAM ▲ or ▼
SET INPUT GAIN	-18dB to +12dB
SET INPUT NAME	16 characters available
AUTO MODE LOAD	OFF, P1-15, A1-15, B1-15
AUTO LEVEL	ON or OFF
S/N OPTIMIZER	ON or OFF

*Affects the currently selected input. Pressing any of the INPUT buttons will select that input for adjustment.

DISPLAY ADJUST	Adjust with PARAM ▲ or ▼
OSD POSITION	Bottom, Center, Top
DISPLAY TIME	Always Off, 2 sec. timeout, Always On
LCD CONTRAST	continuously adjustable
LEVEL METERS	ON or OFF

CONFIG MENU	Adjust with PARAM ▲ or ▼
80HZ HPF	ON* OFF
CENTER	FULL* SMALL NONE
SIDES	THX* STANDARD NONE
REARS	TWO* ONE NONE
SUBWFRS	YES* NO

*factory default settings:

OUTPUT MENU	Adjust with PARAM ▲ or ▼												
INTERNAL SOURCE	<table border="0"> <tr><td>LEVEL MENU</td><td></td></tr> <tr><td>L. FRONT</td><td rowspan="7">-18dB to +6dB</td></tr> <tr><td>CENTER*</td><td rowspan="7">*Not selectable if "NONE" selected in Config Menu.</td></tr> <tr><td>R. FRONT</td></tr> <tr><td>R. SIDE*</td></tr> <tr><td>L. SIDE*</td></tr> <tr><td>SUBWFRS*</td></tr> <tr><td>R. REAR*</td></tr> <tr><td>L. REAR*</td></tr> </table>	LEVEL MENU		L. FRONT	-18dB to +6dB	CENTER*	*Not selectable if "NONE" selected in Config Menu.	R. FRONT	R. SIDE*	L. SIDE*	SUBWFRS*	R. REAR*	L. REAR*
LEVEL MENU													
L. FRONT		-18dB to +6dB											
CENTER*			*Not selectable if "NONE" selected in Config Menu.										
R. FRONT													
R. SIDE*													
L. SIDE*													
SUBWFRS*													
R. REAR*													
L. REAR*													
EXTERNAL SOURCE													

LISTENER POS	Select with PARAM	Adjust with PARAM ▲ or ▼
PANORAMA CALIB	Calibrate Noise	Off, Left Only, Right Only, Left & Right
	Spkr/Lstnr Ang°	29°- 90°
	Listener Pos	L127...Center...R127
REAR DELAY	15-30msec	

SETTING MENU	Adjust with PARAM ▲ or ▼
SETTING LOCK	ON or OFF
CUSTOM NAME	See Manual

The CP-3 Configuration Menu allows a wide range of choices in speaker placement and room setups to maintain optimal performance in almost any room with virtually any speaker system. A table of these menu choices is shown below.

Move cursor with PARAM	CHANGE MENU	Adjust with PARAM ▲ or ▼		
	BUILT-IN HPF	ON*	OFF	
	CENTER	FULL*	SMALL	NONE
	SIDES	THX*	STANDARD	NONE
	REARS	ONE*	TWO	NONE
	SUBWOOFERS	YES*	NO	

*Factory default settings

Setting the Speaker Configuration

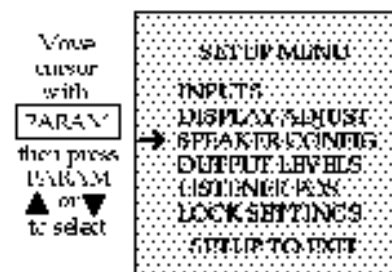

80Hz HPF Turns on and off the High Pass Filter that removes low frequency information from the left, center, right, side and rear outputs (12dB per octave, -3dB at 80 Hz.) Turn ON if you are using THX-certified speakers. You may also want to turn this control ON if you are using small satellite or in-wall speakers throughout the system.

Center Select FULL if you have a full-range center speaker, or if you have set the high pass filter ON.

Use SMALL if your center speaker cannot handle deep bass well. This will automatically engage the Bass Split parameter in the Preset surround modes that use the center, splitting bass out of the center channel and directing it to the main left and right outputs.

Select NONE if there will be no center speaker in the system.

NOTE: The center output is only active in the surround modes, not in Panorama, Ambience or Reverb.

Sides Select THX if THX-type surround speakers are used for the sides. Select STANDARD if any other type of speakers are used, and NONE if there are no side speakers in the system.

NOTE: THX -type surround speakers provide good diffuse envelopment with only two speakers. Additional surround speakers will color the surround information through comb-filtering effects. To prevent this, if THX side speakers are selected in the Speaker Configuration menu, the rear channels are muted in THX mode.

Rears Select the appropriate setting for the number of rear speakers in the system. If you are using only a single rear speaker, or multiple speakers with a single amp channel (mono), select ONE. This speaker should be connected to the left rear output on the CP-3 rear panel. Select TWO if you are using two or more rear speakers.

Subwoofers Select YES if you are using the SUBWOOFER output. (See page 26.)

Setting Input Levels

There are four inputs on the CP-3. Inputs 1, 2 and 3 switch audio and video; Input 4 switches audio only and outputs the video signal from Video Input 1. Each input can be assigned an individual gain level to compensate for sources with different output levels. You can create a name that will be displayed on the screen whenever that input is selected and have each input automatically engage the proper operating mode. For example, Input 1 could have an input level gain of +6dB, display "Video Disc" on the screen, and engage the Home THX Cinema mode.

To obtain maximum performance from the CP-3 (or almost any other signal processor) it is important that the unit be driven to its full input level without overloading. Despite industry attempts at standardization, there is still a wide disparity of output levels among different sources. For example, Compact Discs are often as much as 10-15dB higher in level than video discs. To compensate for this, each of the four inputs on the CP-3 can be assigned a different input gain, assuring optimum performance and consistent volume, regardless of the source selected. The CP-3 can also be set to monitor the input level and automatically optimize the input gain. The CP-3's auto-level and signal-to-noise optimization systems can be defeated for special situations. (The S/N Optimizer is deliberately turned off in the Ambience and Reverb modes.)

Note: When calibrating the input levels, set the system volume to -25dB or higher to ensure optimum meter accuracy. You may engage the System Mute if you do not want to hear the input.

Adjusting Input Parameters

To adjust the input parameters for any of the four inputs, select the input, then press the SETUP button on the remote to call up the main Setup menu. The cursor will be at "INPUTS". (If it is not, select it with PARAM.) Press PARAM ▲ or ▼. The display will show:

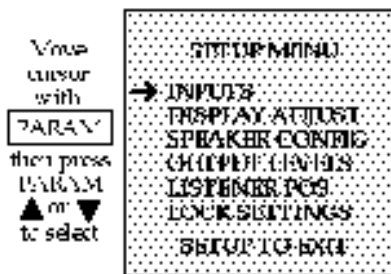

Move cursor with PARAM then press PARAM ▲ or ▼ to select

INPUT NAME	Adjust with PARAM ▲ or ▼
SET INPUT GAIN	-18dB to +12dB
SET INPUT NAME	16 characters available
AUTO GAIN LOAD	ON, 15, 10, 15, BL 15
AUTO LEVEL	ON or OFF
S/N OPTIMIZER	ON or OFF

Whichever the cursor is selected, input, pressing any of the INPUT buttons will select that input for adjustment.

Select the input you want to adjust by pressing the appropriate input select button at the bottom of the remote. Then press PARAM ▲ or ▼. The display will read:

SET INPUT(X) GAIN
MAN+00 AUTO+00dB

The PARAM ▲ and ▼ buttons increase or decrease the input gain for the input you have selected over a range of -18dB to +12dB. Your setting is displayed (in dB) as the MAN (manual) setting. The AUTO setting shows the optimum input level as determined by the CP-3. If the manual level is set too high, causing input overload, the input level will automatically decrease to the point at which it is no longer causing overload.

You can observe this in action by pressing PARAM ▲ until the manual and automatic gain settings are both at +12dB, then play a reasonably loud selection (typically on CD) into this input. You will notice that, while the MAN setting will remain at +12dB, the AUTO setting will decrease until the input is no longer causing distortion. This is an excellent way to determine the optimum setting for the input level. Observe the value of the AUTO setting with a variety of program material and set the MAN gain a few dB above the AUTO setting by pressing PARAM ▲ two or three times.

Following are some general recommendations for level settings:

Compact Disc player: -03dB
 Multi-Disc (Combi) player: +06dB
 Video Disc player: +06dB
 Cassette deck: +03dB
 AM/FM Tuner: +06dB

When you have selected an input level, press STORE to save the setting and return to the Input Menu. Follow this same procedure for each input.

You can assign a name (up to 16 characters) to each of the inputs. This will identify the source whenever an input is selected. In the Input Menu, select "SET INPUT NAME", then press PARAM ▲ or ▼.

The On-Screen display will show the 2-line input name display with the leftmost character on the second line flashing. (The LCD indicates the character being adjusted with an underline cursor.) PARAM ▲ and ▼ will move you forward and backward through the available characters. PARAM will step you to the next character in the name. The sequence of available characters is:

(*) + , - . / 0-9 A-Z *

Note that the On-Screen display uses a blinking asterisk (*) to denote a blank space. On the LCD spaces are blanks with an underscore cursor. Press STORE to save the setting and return to the Input menu.

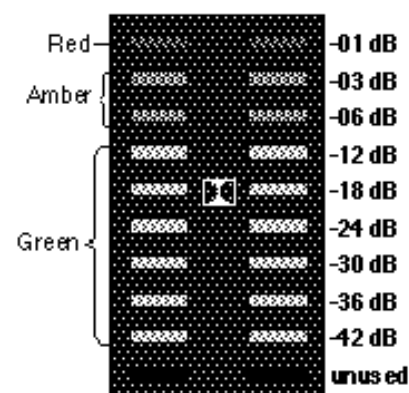

All values are referenced to true clipping, which is 00dB. Values shown are the minimum required to light the LEDs.

If using a Dolby Level test tone, adjust the input level to the point at which the LEDs adjacent to the double-D marker just light.

Assigning Input Names

**Auto-Mode Load
(Automatic Input Mode
Loading)**

Auto-Mode Load determines which operating mode will be engaged when a specific input is selected. For example, the input for a video disc player would load the Home THX Cinema mode, while the input for a CD player would load the Music Surround mode. Any of the preset modes or any of the CP-3's 30 User Registers can be selected — or the current mode can remain unchanged. You can, of course, change the operating mode you are listening to, but if AUTO MODE LOAD is ON, pressing the same input button again will reload the assigned operating mode.

To set Auto-Mode Load, go to the Input menu, select "AUTO MODE LOAD", then press PARAM ▲ or ▼. The display will show which mode is automatically loaded. If the display reads "AUTO MODE LOAD OFF", selecting this input will not change the operating mode and the CP-3 will remain in the same operating mode it was in before this particular input was selected. To change the mode, press PARAM ▲ or ▼ to scroll through the available operating modes. The choices are: OFF, Presets 1-15, Bank A 1-15, Bank B 1-15. Since the Standard remote uses modes stored in User Register B, we recommend selecting one of these five modes for Auto-Mode Load.

Auto-Level

The Input Auto-Level function (see discussion under Setting Input Levels) is normally ON. This can be defeated by using PARAM to move the cursor to select the "AUTO LEVEL" parameter, then pressing PARAM ▼ twice. Now, pressing PARAM ▲ will turn this function ON, pressing PARAM ▼ will turn it OFF. Press STORE to save and return to the Input menu.

Signal-to-Noise Optimization

In addition to controlling the input level, the CP-3 constantly monitors and adjusts the internal signal levels to maximize the signal-to-noise ratio. Theoretically, if the manual input level is set far too high, and you have music or a soundtrack with a very long soft section followed by, say a cannon shot, this may result in a few milliseconds of input clipping. Although we have yet to find a musical selection or a film soundtrack that does this (and, hopefully, the input level will not be grossly misadjusted to begin with) we have provided a control so that you can turn this function off. Under normal operating situations, we recommend it be left on.

The Signal-to-Noise Optimization function is not available in the Reverb and Ambience modes. In other modes it is normally ON. This function can be defeated by using PARAM to move the cursor to select the "S/N OPTIMIZER" parameter, then pressing PARAM ▼ twice. Now, pressing PARAM ▲ will turn this function ON, pressing PARAM ▼ will turn it OFF. Press STORE to save and return to the Input menu.

Note that the S/N Optimizer is selectable for each of the four inputs.

When CP-3 Input and Output levels are set properly, the entire system will be calibrated to play films at the level intended by the director. Setting the output levels is easy, particularly if a Sound Pressure Level (SPL) meter is used. Using the PARAM and the PARAM ▲ and ▼ buttons, adjust the level of each individual output until they are all the same relative level. You can use an external source for this, or the CP-3's internally generated calibration signal.

Temporarily turn the system volume down to about -20dB. Press SETUP and use the PARAM button to select OUTPUT LEVEL. Then press PARAM ▲ or ▼. The display will read:

INTERNAL SOURCE
EXTERNAL SOURCE

Use the PARAM button to select the built-in signal generator (INTERNAL SOURCE) or an EXTERNAL SOURCE. With your choice selected by the cursor, press PARAM ▲ and ▼ to activate your selection. PARAM is used to select the output to be adjusted; PARAM ▲ and ▼ raise and lower the level of that output in precise 1dB increments. The Level sub-menu choices are shown below.

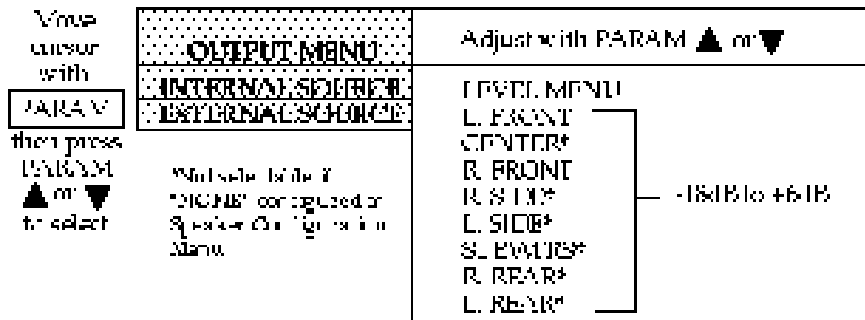

Note that selecting INTERNAL SOURCE automatically disconnects all audio and video inputs, and plays only one channel at a time. EXTERNAL SOURCE allows all channels to be heard simultaneously.

If you are using an SPL meter, use the C-weighting with the meter response on SLOW. From your listening position, hold the meter at about ear level at arm's length (to avoid body interference). A tripod is useful here. Aim the microphone at the ceiling and set to a scale incorporating 75dB. Increase the system volume to 00dB. Now use PARAM ▲ and ▼ to raise or lower the output level of the speaker until the meter reads 75dB. Press PARAM to select the next channel specified in the Configuration menu and continue in this manner through all the channels.

Be sure to record the values on the Installation Worksheet provided at the end of this manual. Press SETUP to save the settings and return to the Setup menu.

Setting Output Levels



NOTE: When you select the Output menu, the CP-3 automatically engages the Home THX Cinema mode. When you exit the Output menu, the system will return to the previously selected mode.

PAL and SECAM

NOTE: Because the CP-3 is not capable of generating PAL or SECAM composite video signals by itself, during INTERNAL NOISE generation (when all inputs are turned off) users with PAL or SECAM TVs will have to rely on the LCD when adjusting Output Levels.

In the absence of an SPL meter, it is possible to set the output level by ear. Use the built-in signal generator in the CP-3 to adjust all volumes to be the same as they cycle around the various speakers. Depending on timbre variations between your speakers, this may be difficult to judge, get as close as you can. The system should be reasonably well balanced, although not actually calibrated for precise playback level matching. With the system volume at 0dB, the internal noise source should be at the same level at which film dialog sounds comfortable.

NOTE: If the CP-3 is connected in the tape monitor or signal processor loop of a preamp, integrated amp, or receiver, or if any of the amplifiers used in the system have gain (volume) controls, the level settings on them will affect the balance of the CP-3 outputs. Generally, the gain controls of these amps should be set at or near maximum. You should record the values of these controls on the Installation Worksheet provided at the end of this manual for later reference.

Subwoofers

The SUBWOOFER output is created by summing the left and right inputs, then filtering out frequencies above 80Hz at a rate of 24dB per octave. For the tragically technical, this is a Linkwitz-Riley LPF -6dB @ 80Hz. Many of the better subwoofers have their own crossover (complementary low and high pass filters) and amp built in. With these, it is often better not to use the CP-3 SUBWOOFER output which has already been filtered. Instead, connect the CP-3 main (FRONT) left and right outputs to the inputs of the subwoofer crossover. Connect the CP-3 SUBWOOFER output to the amplifier driving the main speakers. This has the advantage of bi-amping: all the low bass is handled by the subwoofer; the main speakers handle only mid-bass and up (usually resulting in better-sounding main speakers). If you want to run the main speakers full range, the sub can be wired in parallel to the main amp using a Y-connector.

Be sure to turn the 80Hz HPF in the Speaker Config menu to OFF. Since the center channel will now be running full range, select SMALL center in the Speaker Config menu. This turns on the BASS SPLIT parameter in the Preset modes, splitting low frequencies off the center channel and feeding them to the left and right front outputs. Remember to adjust this parameter in any User registers you program, as it is initially set to BYPASS. A little experimentation goes a long way in determining the optimum value for BASS SPLIT. Usually, a cutoff between 63Hz and 140Hz is best. Too high a cutoff will make some male vocals sound chesty; too low a cutoff causes bass loss.

Now the center channel is rolled off and the main left and right are crossed over by the subwoofer. You do not need to be as concerned with the surrounds because the Dolby encoder rolls off most of the bass below 100Hz. Some films, however, do have substantial LF information in the surrounds and the CP-3 music modes do not limit low frequencies at all. (Although the effects channels are typically using less than 25% of the power used in the mains.) Unless you plan on very high sound pressure levels and want lots of bass, most systems will not require subs on these channels. Obviously, the most efficient way to add subs is to utilize the crossover in the CP-3.

The Listener Position must be calibrated for the Panorama mode and the Panorama Effect parameter in Reverb and Ambience modes to work optimally. Calibration of the listener position is performed from the setup menu. Press SETUP, then select "LISTENER POS".

Calibrating the Listener Position

Move cursor with	LISTENER POS	Select with	Adjust with
PARAV	PANORAMA CALIB	Calibrate Noise	OFF, Left Only, Right Only, Left & Right
Move cursor with	LISTENER POS	SPKR/LSTNR ANG°	20° - 90°
PARAV	LISTENER POS	Listener Pos	LEFT, Center, RIGHT
Move cursor with	LISTENER POS	15-50msec	

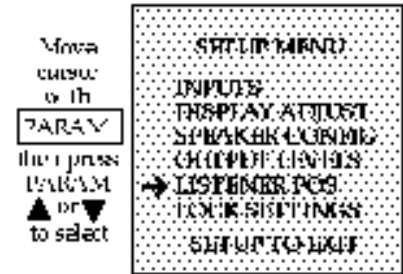

Panorama works by canceling the sound going from each speaker to the opposite ear. Its effectiveness is highly dependent on the geometry of your front loudspeakers, the room and your listening position. The correct timing of the canceling signal varies with the relative angle between your main speakers. Although not necessary for calibration, understanding the principle behind Panorama will help in understanding the adjustments you will be making. Refer to the section on Panorama in the Theory & Design booklet.

Find a mono source, such as an announcer on FM radio or a mono film, and listen for a tightly focused center image of speech or singing. If the image is off-center, adjust the CP-3's BALANCE controls. (The more centered the monaural image, the better Panorama will work.)

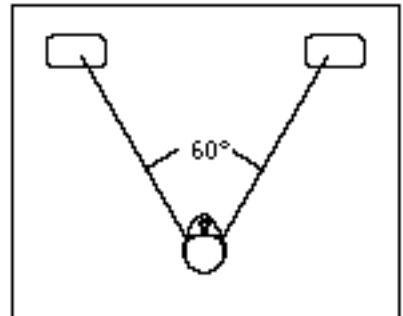

SPKR/LSTNR ANG° is the angle between the main speakers as seen from the listening position — here it is about 60°.

CALIBRATE NOISE is a special digitally generated signal to aid in calibrating the Panorama mode. The signal can be set for the left side, the right side, or both. Note that in all cases, sound will actually be produced by both front loudspeakers. The adjustments in this mode effect the *perceived* directionality of the sound

The speaker/listener angle, displayed in degrees (SPKR/LSTNR ANG °), adjusts for wide or narrow speaker spacing (relative to the listening position). For the two canceling signals to arrive at both ears at the same time you must be centered precisely between the speakers. The Listener Position (LSTNR POS) parameter delays the corrections from either channel and allows adjustment for an off-center listening chair or for asymmetrical speaker placement.

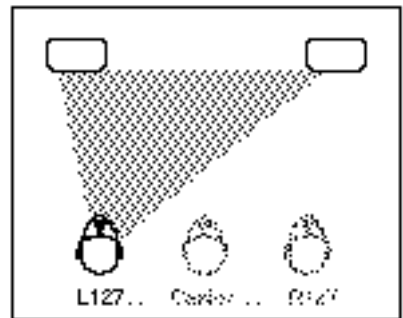

LISTENER POS allows you to adjust for an offset listening position.

It will be easiest to calibrate this mode if you start equidistant from the two front speakers, even if this is not your normal listening position. Once you have heard the effect and set the speaker/listener angle, the Listener Position parameter will allow you to “move” the effect to your customary listening position.

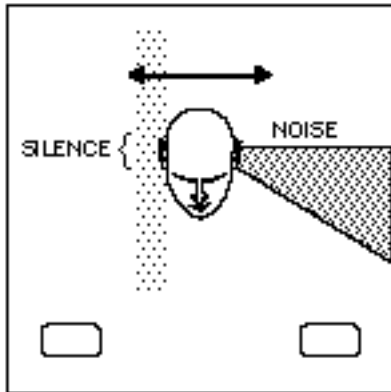

Move your head from side to side to find the position where the noise is full left, and the right ear hears near total silence.

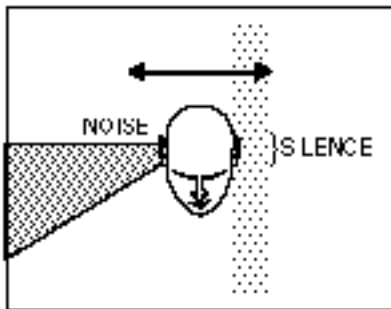

When calibrating right, if your left ear is in the silent band, the speaker angle is correct.

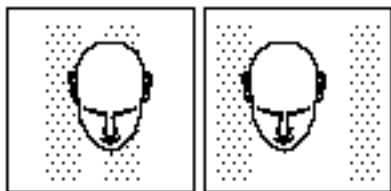

If the two silent bands are too close, lower the Speaker Angle; if they are too far apart, raise the Speaker Angle.

From the Setup menu, use the PARAM button to select the LISTENER POS menu, then press PARAM ▲ three times to show the following display:

CALIBRATE NOISE
CALIBRATE LEFT ONLY

If you are symmetrically centered between the two front speakers, the test signal should sound as though it is coming from off to your left side, well beyond the left speaker, with near-total silence in your right ear. Still facing forward, move your head from side to side until the effect is strongest. To make sure you have found this *sweet spot*, press PARAM to call up the following display:

SPKR./LSTNR ANG °
XX

Press the PARAM ▲ and ▼ buttons until you hear the strongest effect. (When you have found it, you will notice an almost physical sensation of silence in your right ear.) Push PARAM repeatedly until you return to the CALIBRATE LEFT ONLY display.

Press PARAM ▲, the display will read:

CALIBRATE NOISE
CALIBRATE RIGHT ONLY

Again, shift your head from side to side to find the sweet spot, this time looking for the point where the sound is strongest in your *right* ear. Compare the locations of the two sweet spots by pressing PARAM ▼ to call up LEFT ONLY, then pressing PARAM ▲ and ▼ to toggle between LEFT ONLY and RIGHT ONLY.

If the sweet spots do not coincide, press PARAM to return to the SPKR./LSTNR ANG ° display. If the first sweet spot is to the *left* of the second, press PARAM ▲; if it is to the *right*, press PARAM ▼.

If your normal listening position is not centered between your two front speakers, once you have correctly set the speaker angle, you may want to "move" the sweet spot to that position. To do this, press PARAM to get to LISTENER POS and use PARAM ▲ and ▼ to move the effect. As you adjust the position, the display will indicate motion to the left of center (L001,L002,L003...L127), CENTER, or to the right of center (R001,R002,R003...R127). The numbers represent approximately 1/3", but are provided primarily as a general reference.

The Panorama mode is now calibrated. Press the SETUP button to store these settings and return to the main setup menu.

When presented with several similar sounds (as in the case of surround sound) we tend to localize on the first sound we hear. Because rear speakers are often closer to the listening area than the main speakers, occasional leakage of the front channel sound into the surround speakers can be audible and distracting. Delaying the sound from the rear speakers gives the sound from the front a chance to reach the listener before the surrounds kick in.

The REAR DELAY control in the LISTENER POS menu allows you to set this delay at 15-30 milliseconds. The best setting will depend on the distance between the main listening area and the front speakers, and the distance between the main listening area and the surround speakers.

From the Setup menu, press PARAM to select "LISTENER POS", then press PARAM ▲ to display the LISTENER POS menu. Now use PARAM to select REAR DELAY, then use PARAM ▲ and ▼ to adjust the delay time.

Refer to the graph shown at the right for the best setting for your particular situation. Measure the two distances and note where they intersect on the graph. The shaded areas indicate the optimum delay settings.

Note that the delay setting you choose here will only affect those surround modes which do not have their own rear delay parameter.

Setting Rear Delay

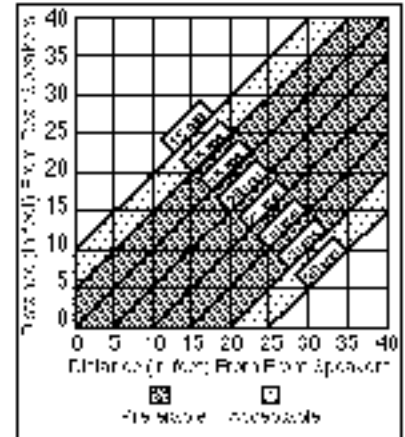

Rear Delay Settings

Customization

Locking In Settings

After you have calibrated and customized the CP-3, there are two additional steps recommended to safeguard the settings:

First, document your adjustments on the Installation Worksheet (provided at the end of this manual) if you have not already done so.

Second, consider locking the settings in so that they cannot be inadvertently changed. Locking the settings will allow full operation with the Standard remote, but will limit the Expanded remote's ability to change operating parameters. Specifically, with the Settings Lock ON, the Expanded remote will function normally but will not be able to change values in the Setup menu or any parameters. The PARAM button will function normally, so the parameters can be selected, but pressing either PARAM ▲ or ▼ will simply display the parameter value and yield a "SETTINGS ARE LOCKED" message.



To lock the settings, press SETUP and select "LOCK SETTINGS".

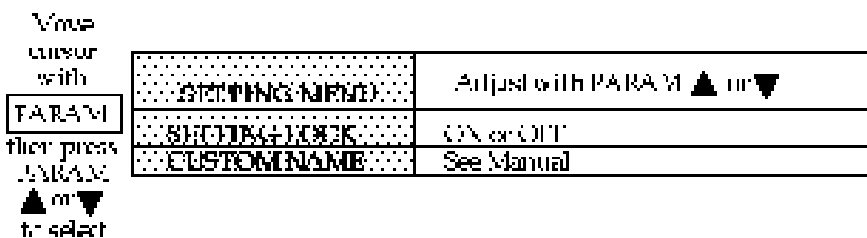

With LOCK SETTINGS selected, press PARAM ▲ twice to select the Lock Settings parameter and engage it. To turn the lock off, follow the same procedure but press the PARAM ▼ button instead of PARAM ▲ until the display reads:

SETTINGS LOCK
OFF

Custom Name

When the CP-3 is first turned on, it will display a copyright notice with the current software version. The next screen will say:

CUSTOMIZED FOR
DEMONSTRATION

The word "demonstration" can be replaced with the owner's name (up to 16 characters). The name assigned here can only be changed with the following procedure. It will not be deleted even when the Restore Defaults procedure (see Chapter 4) is performed.

To do this call up the Setting menu as described above and move the cursor to select "CUSTOM NAME". Press PARAM ▲, then press BANK to unlock the custom name. The PARAM button will now move the cursor to one of 16 available spaces in the display, while PARAM ▲ and ▼ cycle through the available list of characters, beginning with the one currently occupying the space.

At this point an underline character appears in the bottom row of the LCD display. (On the on-screen display, one of the characters of the current name will flash.) The cursor will move to the leftmost character of the mode name. Now push PARAM ▲ or ▼ until the character you want appears in the space. (Holding either button for one second activates an auto-repeat mode to speed you through the list.) All letters are available, in upper case, as are digits 0-9, a blank space and an assortment of other characters. When the first space in the display is correct, press PARAM, use PARAM ▲ and ▼ to set the second character and repeat until the new name is complete.

Press SETUP to exit to the main Setup menu. Press SETUP again to resume normal operation.

Lastly, the CP-3 is designed to be operated day to day with the Standard Remote. Unless you are an incorrigible tweaker, simply put the Expanded Remote away, with its batteries removed for safe keeping.

Custom Modes

When the CP-3 is powered up via the Standard remote, it will automatically restrict itself to the five operating modes in User Bank B that correspond to those listed on the remote. These modes are stored in registers B2, B6, B11, B10, and B15. Since these modes are stored in User registers, it is possible to change these modes so that a new operating mode is engaged when one of the five mode buttons on the Standard remote is pressed. For instance, you may choose to have NIGHTCLUB load a small Ambience hall instead of the default Panorama Wide mode — To do this, simply load the small Ambience hall into register B2. Of course you can also adjust any of the parameters in the mode. Adjustments will be saved automatically.

Mode:	loads register:	default preset:
NIGHTCLUB	B2	PANORAMA-WIDE
CONCERT HALL	B6	AMBIENCE-LARGE HALL
MUSIC SURROUND	B11	SURROUND- MUSIC LOGIC
TELEVISION	B10	SURROUND-TELEVISION
MOVIES	B15	SURROUND-HOME THX

Modifying the Mode

Chapter 3 describes the CP-3's four basic modes and all of their variable parameters. Any changes in the parameters of a mode in the User bank will be automatically recorded and stored for future use. The CP-3 also allows you to store a new version of any Preset or User mode in any User register.

Storing a mode

In addition to the 15 Preset modes set at the factory, there are 30 User registers (Bank A 1-15 and Bank B 1-15) that can be used to store customized versions of the original modes. Any of the parameters that can be accessed and changed with the Expanded remote can be used to modify the modes. Left/Right BALANCE and VOLUME settings are considered system parameters and are not stored with each mode. EFFECT LEVEL, Front/Rear BALANCE, and parameters listed in the parameter menu, will be memorized in this new mode if it is stored in a User register.

If you modify a Preset (or the contents of any User register) and want to make a copy of it, press STORE. The display will read:

```

STORE MENU
>STORE THIS MODE
SET MODE NAME.
    
```

Press PARAM ▲ once and the display will read:

```

(12-letter mode name)
  |
  v
PUT PRO LOGIC
IN A1 PAN NORM
  /   \   \
  (User reg #) (Mode type) Mode name
                1st 3 letters) (1st 4 letters)
    
```

The top line of the display will show the mode you are about to save. The second line shows the location (and current contents) of the register where the mode will be saved.

If you wish to store your new mode into the register shown, simply press STORE. This will erase the register contents and replace it with your new mode.

If you want the mode stored in a different location, press PARAM ▲ to display (and select) the next register. Repeatedly pressing PARAM ▲ will step you through all 15 User registers in Bank A, then through all 15 User registers in Bank B. (PARAM ▼ allows you to step back down through the list.) When you find the register you want, press STORE.

If you want to exit without copying your new mode, press SETUP to return to the operating mode you were in when you began the store procedure.

To rename any mode, press the STORE button. The display reads:

Renaming a mode

```
STORE MENU
>STORE THIS MODE
SET MODE NAME.
```

Move the cursor to select "SET MODE NAME". The PARAM button will now move the cursor to one of twelve available spaces in the display, while PARAM ▲ and ▼ cycle through the available list of characters, beginning with the one currently occupying the space.

At this point an underline character appears in the bottom row of the LCD display. (On the on-screen display, one of the characters of the current name will flash.) The cursor will move to the leftmost character of the mode name. Now push PARAM ▲ or ▼ until the character you want appears in the space. (Holding either button for one second activates an auto-repeat mode to speed you through the list.) All letters are available, in upper case, as are digits 0-9, a blank space and an assortment of other characters. When the first space in the display is correct, press PARAM, use PARAM ▲ and ▼ to set the second character and repeat until the new name is complete.

Press SETUP to return to the Store menu. Use PARAM to select "STORE THIS MODE", then use PARAM ▲ and ▼ to step to the register where you want this mode stored. Once you have selected a location, press STORE.

Note that, if you have renamed a Preset, you must store the newly-named mode in a *User register* in order to have your change saved.

The CP-3 contains four basic operating modes: Panorama, Ambience, Reverb and Surround. Each of these modes is labeled on the Expanded remote, with its variations. Pushing one of the buttons numbered 1-15 during normal operation will load that mode. Whenever the CP-3 is turned on, it will load the mode that was running when it was turned off.

Each mode has a number of parameters that you can vary with the three PARAMETER buttons. The parameters for each mode are described later in this section. Pressing PARAM displays the parameters available for the mode you are using, with a cursor marking the currently adjustable parameter. The first time you press either PARAM ▲ or ▼, the current value of the parameter will be displayed. After that, pressing PARAM ▲ will increase the value of the parameter (or turn the function ON), pressing PARAM ▼ will decrease the parameter value (or turn the function OFF). This will be true even if you have set the display to time out and the parameter is no longer shown on the screen.

The CP-3 contains a total of 45 mode registers organized into three Banks of 15. Each of the 15 mode buttons will load one of the factory Presets labeled on the Expanded remote, or one of the 15 User registers in Bank A or B, depending on which Bank you have chosen. The BANK button toggles between the Preset Bank and the two User Banks. For example, if you are running USER A 7, pressing BANK will switch to USER B 7, pressing BANK again will switch to PRESET 7, pressing it again will switch back to USER A 7, and so on. The factory Preset modes are denoted by the label: PRESET in the upper left of the display, with the mode number beneath. The mode title appears in the right half of the display, with the mode name above and the variation below.

While running a Preset you can change any of its parameters to see how they affect the sound. These changes will be lost when you turn the CP-3 off or when you change modes, unless you explicitly store the changes. (See Page 32.) **Changes made in the value of parameters within a User mode, however, are stored immediately and automatically.** This includes settings of EFFECT LEVEL and FRONT/REAR BALANCE, but not of the LEFT/RIGHT BALANCE or VOLUME controls. You do not have to perform any specific storage routine to create a new variation in a User register; it happens whenever you change a parameter.

When the CP-3 leaves the factory each User register contains a duplicate of the Presets. If you maintain this arrangement, the labels on the remote will continue to describe the contents of both registers. You can, however, store a version of any mode in any of the User registers. For instance you can store a Reverb mode in User Register A1 even though button 1 on the expanded remote is labeled PANORAMA NORMAL.

The CP-3's User registers can be cleared and reloaded with duplicates of the factory Preset modes at any time. Refer to Chapter 4 Troubleshooting: *Restoring Defaults*.

Using the Modes

Presets and User Registers

Panorama Panorama extracts the natural ambience from recorded music and moves it outward from the speakers, producing greater width and depth of image and a feeling of enhanced spaciousness. This mode adds no additional sound but expands the existing stereo image. Panorama also works with Dolby Stereo movies, bringing the surround track outward into the room.

Panorama works with just two loudspeakers. The front speakers are driven entirely from the CP-3's digital circuits. Panorama will also send a stereo difference signal (left channel minus right or vice-versa) to the side and rear loudspeakers if you have them. NORMAL (1) will provide enough expansion for most music, while WIDE (2) has a more pronounced effect on the image. BINAURAL (3) has special low-frequency compensation and is meant specifically for true binaural recordings made with a dummy head.

Panorama NORMAL is designed to work with recordings whose bass energy is evenly distributed across the stereo image. Panorama WIDE is designed for recordings with centered bass (almost all pop and rock). The only other difference between these two modes is their initial EFFECT LEVEL. If you need more bass from Panorama NORMAL, switch to WIDE and reduce the EFFECT LEVEL. Conversely, if Panorama WIDE is too bass-heavy, switch to NORMAL and increase the EFFECT LEVEL.

The location of the front speakers and the listening position are crucial to Panorama's effectiveness and for best results your system and the CP-3 together should be set up and calibrated according to the procedure in Chapter 2. The strength of the Panorama effect drops off as you move away from the prime listening position, especially to the sides. Video systems with the main loudspeakers spaced closely on either side of a TV screen will produce a usable effect over a somewhat wider area than set-ups with a large included angle between the speakers.

EFFECT LEVEL sets the amount of crosstalk cancellation, and thus the apparent front width. When EFFECT LEVEL is all the way down, INPUT BALANCE, LF WIDTH and the rear outputs are still active.

Panorama Parameters

Parameter	Initial Value	Range
MODE SELECT	(1) NORMAL	01-03 BINAURAL
EFFECT LEVEL	0	-20 to +20
INPUT BALANCE	0	CP-1-12
LF WIDTH	0.5	0.25 to 1.0
REAR OUTPUT	0	0 to 100%

INPUT BALANCE compensates for the occasional source with audible channel imbalance. It is especially important when using Panorama for movies. If the movie sound tracks are unbalanced, the dialog will wander away from the center; adjusting the Input Balance corrects for this.

LF WIDTH controls the amount of low-frequency spatial correction that is applied to the signal. A positive value of LF WIDTH means the difference (left minus right channel) signal has additional energy below 500 Hz, while the sum (left plus right) signal has correspondingly less. (Negative settings can compensate for recordings with too much of this property.) LF WIDTH can add needed spaciousness and warmth to classical recordings made with coincident or near-coincident miking. (See the Theory and Design booklet.)

REAR LEVEL adjusts the loudness of the signals sent to the rear channels. This control should be set so that the rear is audible without calling attention to itself.

REAR ROLLOFF sets the frequency above which the rear-channel sound is attenuated. It should be high enough to give presence and airiness to the rear sound, but not so high as to place distracting instrumental overtones or other sounds behind you. The appropriate setting will vary with the program material.

REAR DELAY adjusts the amount of time between the appearance of a signal in the front channels and its emergence from the rear. Generally, the correct delay is about 16 milliseconds but the setting depends on speaker set-up and source material. In general, the delay should not be so great that the rear sound becomes identifiable as a distinct source.

NOTE: If the system is configured with *only* side speakers, the REAR LEVEL, REAR ROLLOFF and REAR DELAY settings will affect the *side* outputs. If the system has both side and rear speakers, these parameters control them both.

In Panorama, MAIN MUTE mutes the front outputs; EFFECTS MUTE mutes the side and rear outputs.

The center channel is not used in the Panorama mode.

Ambience

Ambience generates the appropriate early reflections for stereo simulation of one of six different halls — one rectangular hall and one fan-shaped hall in small, medium and large sizes — and sends the reflections to the side and rear speakers. For systems without side speakers, Ambience also incorporates a version of Panorama that will spread the stereo image and add the reflections it generates to the expanded sound stage.

EFFECT LEVEL adjusts the loudness of the side and rear speakers. When there are no side speakers, it adjusts the amount of ambient signal mixed

Ambience Parameters

Parameter	Initial value	Range
ROOM SHAPE	Rectangular	Rectangular, Fan
ROOM SIZE	3.00 meters	0.50 - 10.00 meters
LIVENESS	1	1 - 6
ROLLOFF	1.00 meters	0.50 - 10.00 meters
PANORAMA EFF	0%	0 - 30%
EFFECT LEVEL	0%	0 - 100%

* 0 if configured with side speakers (Presets only)

into the main loudspeakers. This control should be adjusted as high as possible without making the extra speakers individually audible.

ROOM SHAPE selects one of two basic hall shapes, rectangular or fan. Refer to the Theory and Design booklet for a discussion of the properties of the two.

ROOM SIZE allows you to change the room size in fine graduations within the overall hall size you have selected. For convenience, the hall size is denoted by length in meters.

The LIVENESS parameter adjusts the amount of recirculation within the mode. The higher the value, the more reflective the surfaces of the simulated space and the longer the sound will take to decay. At very high values the decay is audibly less smooth than in the Reverb modes, which are more effective at simulating very live spaces.

ROLLOFF mimics the absorption of the air in the hall and its initial value is therefore more pronounced (the rolloff begins at a lower frequency) the larger the space.

PANORAMA EFFECT adjusts the strength of the signal used to expand the stereo image outward from the front two speakers. It is only needed when

side speakers are absent. (If the system is configured without side speakers, the signal normally sent to the sides will be mixed into the front outputs.)

SPEECH DETECT The Speech Detection circuit distinguishes monaural speech from other inputs. Essentially, this control turns down the effect to make speech clearer. Whenever stereo signals are present, the right and left input channels are used independently as inputs to the ambience synthesis. If there is a strong monaural speaking voice present at the same time, this component of the input to the Ambience algorithm is reduced while the stereo component is increased.

If the input signal is pure monaural speech the input is almost entirely attenuated. **SPEECH DETECT** is a real benefit to some popular music (where spoken voice, such as rap, occurs along with music), stereo television, and early stereo movies. Any stereo material which was not carefully mixed for Surround is a good candidate for playing through Ambience with **SPEECH DETECT** on.

In Ambience, **MAIN MUTE** mutes allows you to hear only the CP-3 generated effects; **EFFECTS MUTE** allows you to hear the original, unproc-

Reverb essed stereo signal.

Note that the S/N Optimizer is not active in this mode.

The Reverberation mode differs from Ambience in that it does not simulate the early reflections of specific halls, but emphasizes rich, smooth reverberant decay in small, medium or large spaces. It works well for simulating a space with a long reverberation time relative to its size, such as a reverberant chamber, or a church. For systems without side speakers, Reverb also incorporates a version of Panorama that will spread the stereo image and add the reflections it generates to the expanded sound stage.

EFFECT LEVEL adjusts the loudness of the side and rear speakers. When

Reverb Parameters

Parameter	Initial Value	Range
MID RT	0.45 sec	0.35 - 0.55 sec
BASS RT	0.95 sec	0.64 - 1.35 sec
ROOM SIZE	1.00 m	0.25 - 1.75 m
PRE-DELAY	0	0 - 100 ms
EFFECT LEVEL	0%	0-30%
REAR EFFECT	0%	0-100%
TRAIL OFF	0.50 - 0.75 sec	0.12 - 1.50 sec

* 0 if configured with no side speakers (Presets only)

there are no side speakers, it adjusts the amount of ambient signal mixed into the main loudspeakers. This control should be set as high as possible without making the extra speakers individually audible.

MID RT (Midrange Reverberation Time) is the time required for midrange sounds to decay 60 dB in level. Your choice of small, medium or large synthesized space determines both the initial value and the available range of MID RT.

BASS RT, the low-frequency reverb time, depends on the MID RT and is expressed as a multiplier. BASS RT is equal to MID RT in SMALL (mode 7), while in the LARGE version of the mode it is 25% higher (as is the case in most actual halls with acceptably warm subjective frequency balance).

ROOM SIZE changes the size of the room by increasing or decreasing the effective length of the hall (expressed in meters).

PRE-DELAY increases the delay between the direct sound and the onset of reverberation. Some pre-delay is inherent in the programs, and the preset

value of 0 is usually a good starting point. Increasing the pre-delay will make the hall sound larger.

PANORAMA EFFECT adjusts the strength of the signal used to expand the stereo image outward from the front two speakers. Its initial value is zero, unless you have configured the CP-3 for no side loudspeakers.

SPEECH DETECT The Speech Detection circuit distinguishes monaural speech from other inputs. Essentially, this control turns down the effect to make speech clearer. Whenever stereo signals are present, the right and left input channels are used independently as inputs to the ambience synthesis. If there is a strong monaural speaking voice present at the same time, this component of the input is reduced while the stereo component is increased.

If the input signal is pure monaural speech the reverb effect is attenuated. SPEECH DETECT is a real benefit to some popular music (where spoken voice, such as rap, occurs along with music), stereo television, and early stereo movies.

TREBLE ROLLOFF, as in the Ambience mode, is preset to mimic air absorption in actual spaces, being more pronounced in the larger ones.

In Reverb, MAIN MUTE mutes allows you to hear only the CP-3 generated effects; EFFECTS MUTE allows you to hear the original, unprocessed stereo signal.

Note that the S/N Optimizer is not active in this mode.

Surround

The SURROUND modes make full use of additional loudspeakers at the center, sides and rear of the room. TELEVISION provides surround effects for television viewing of monaural, stereo, and stereo synthesized programs. MUSIC is a 7-channel ambience extraction mode, appropriate for any type of music. It also provides a unique way to listen to films, particularly stereo films which are not Dolby surround encoded. FULL (Full Range) allows unprocessed music to be played over all the speakers for background music, or for maximum acoustical output of the system. MONO LOGIC takes a monaural soundtrack and sends music and sound effects to the sides and rear through a room simulator mode, while keeping dialog in the center. PRO LOGIC is Lexicon's all-digital implementation of the Dolby Pro Logic Surround decoding process. Home THX Cinema is designed for any surround sound encoded movies, music, or television programs.

Because each Surround mode makes use of different configurations, the EFFECT LEVEL control will be described separately at the beginning of each set of parameter descriptions.

Surround Parameters

Television

Parameter	Initial Value	Range
CENTER EFFECT	ON*	Turn on 1 to
AUTO AZIMUTH	OFF	ON/OFF
BYPASS	By Pass, 63 Hz**	By Pass, 63 Hz
SUB BASS BOOST	OFF	OFF, Full, 125 Hz
REAR POLY OFF	63 Hz*	125 Hz, 63 Hz*
REAR POLY ON	OFF	ON/OFF
EFFECT LEVEL	OFF	ON/OFF
PROLOGIC	OFF	ON/OFF
SUBSERVANTS***	FRONT	Front, Rear

* Phantom if configured with no center speaker

** BYPASS if center speaker configured as NONE or FULL;
63 Hz if configured as SMALL (Presets only)

*** Inaccessible if side speakers configured as THX or NONE

EFFECT LEVEL controls the loudness of the front, side and rear outputs.

CENTER EFFECT The essence of the Television mode is that dialog, music and sound effects are dynamically directed to the output channels, a process called steering. The CENTER EFFECT control allows you to adjust the amount of steering in the front channels. Increasing this parameter will increase the separation between the center and the main left and right channels. Selecting OFF will steer the center signal to both the left and right channels.

The AUTO AZIMUTH/BAL (short for Auto Azimuth Error Correction/Automatic Input Balance) parameter should be set to ON for films, OFF for

music. When it is on, special patented algorithms continually monitor the input signal and adjust both the relative level and time offset of the two channels to keep the dialog properly centered and special effects properly localized. This automatic feature is why the CP-3 does not have or need an input balance control for Dolby Surround decoding.

BASS SPLIT takes the low bass from the center, where it is in many film and music mixes, and distributes it instead to the left and right front-channel speakers. Bass Splitting is valuable because in many video installations the center speaker is smaller than the two main stereo speakers and less capable of handling the lowest frequencies. By directing the low frequencies to the main speakers, there is less risk of damage to a small center speaker and no loss of bass information since it will be reproduced by the main speakers.

SUB BASS BOOST boosts or cuts the subwoofer output level. Although the normal subwoofer level was set during the initial calibration procedure, with some recordings you may find it desirable to increase or decrease this deep bass level.

REAR ROLLOFF sets the cutoff frequency of a low pass filter in the rear channel. Frequencies above this setting are attenuated. This control should be set high enough to give presence and airiness to the rear sound, but not so high as to place distracting instrumental overtones or other sounds behind you. The appropriate setting will vary with program material.

REAR DOLBY B Dolby Surround decoding specifications call for a special form of Dolby B-type noise reduction for the rear (surround) channel. Since Dolby Surround encoded material should generally be listened to in the ProLogic or THX modes, this parameter is normally OFF. It can, however, be turned ON if you wish to experiment with this.

The **RE-EQUALIZER** equalizes the left, center and right channel outputs to match the overall frequency balance of the original recording. Without this re-equalization, many films, and some television programs, will sound too bright.

DECORRELATE electronically "scrambles" the monaural surround channel to provide added spaciousness and envelopment.

SIDE SPEAKER ASSIGN determines whether the information fed to the side outputs is derived from the front left and right, or from the rear. Choosing the front setting will create a very wide soundstage, which can be very exciting on some soundtracks. On others, particularly those with panned dialog and very tight localization of sound effects, the soundstage will be too wide. Technically, the rear setting is a closer match to the original recording format.

In Television, **MAIN MUTE** mutes only the center output; **EFFECTS MUTE** mutes the center, side and rear outputs.

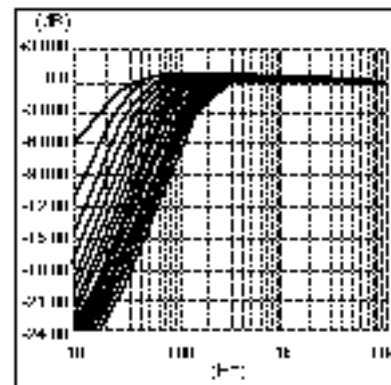

Bass Split

Bass Split rolls off frequencies at 6dB per octave. The values given are at the -3dB point of attenuation from the center speaker.

Music

Parameter	Initial Value	Range
CENTER LEVEL	0%	0% - 100%
CENTER DELAY	Time	0 - 110ms
SIDE LEVEL	0dB	-10dB to +10dB
SURROUND EFFECT	MUSIC	FILM or MUSIC
BASS SPLIT	63 Hz	BYPASS or 63 Hz
BASS SPLIT DELAY	Time	0 - 110ms
REAR CHANNEL	ON	OFF or ON

* OFF if configured with no center speaker

** BYPASS if center speaker configured as NONE or FULL;
63 Hz if configured as SMALL (Presets only)

EFFECT LEVEL controls the loudness of the center, side and rear outputs.

CENTER LEVEL attenuates the level of the center channel and can turn it off completely. The proper setting for this control will vary depending on the recording and your taste. There is no "correct" setting.

CENTER DELAY provides a delay of the center channel. When the center speaker is closer to the central listening position than the main left and right speakers, the sound from it will arrive at the listener just slightly ahead of the sound from the main left and right speakers. Depending on your speakers and your room, adjustment with this control can be dramatic, or quite subtle. Adjustment will be easiest with **CENTER LEVEL** set to Maximum, listening to music with a strongly centered vocalist. Listen for tight localization and a smooth blend between the three front speakers.

SIDE LEVEL controls the volume level of the side speakers. Since Music Surround is a dynamic ambience extraction mode, the effect of the side speakers will depend on the recording. Although the default value is 0, the correct setting will vary with each recording, your room, and your personal taste.

SURROUND EFFECT allows you to optimize the Music Surround mode for music listening or for films. When set to **FILM**, the Auto Azimuth Error Correction, Rear Dolby B and rear steering are all turned ON. When set to **MUSIC**, they are all turned OFF.

BASS SPLIT takes the low bass from the center, where it is in many film and music mixes, and distributes it instead to the left and right front-channel speakers. Bass Splitting is valuable because in many video installations the center speaker is smaller than the two main stereo speakers and is less capable of handling the lowest frequencies. By directing the low frequencies to the main speakers, there is less risk of damage to a small center speaker and no loss of bass information since it will be reproduced by the main speakers.

REAR ROLLOFF sets the frequency above which the rear channel sound is attenuated. It should be high enough to give presence and airiness to the rear sound, but not so high as to place distracting instrumental overtones or other sounds behind you. The appropriate setting will vary with program material.

REAR DELAY Since the rear channel in Music contains extracted ambient information, it typically does not need as much delay as the film surround modes. This delay can be adjusted between 8-30 milliseconds. It should not be set so high as to create a distinct echo in the rear.

DECORRELATE electronically "scrambles" the monaural surround channel to provide added spaciousness and envelopment through the stereo outputs.

In Music, **MAIN MUTE** mutes the front outputs if the system is configured with side speakers, otherwise it is inactive; **EFFECTS MUTE** mutes the center, sides and rear outputs.

Full Range

Parameter	Initial Value	Range
CENTER LEVEL	0dB	-10dB to +10dB
HIGH PASS	100Hz	Bypass to 10kHz
SUB BASS BOOST	0dB	-10dB to +10dB

EFFECT LEVEL controls the loudness of the center, side and rear outputs.

CENTER LEVEL attenuates the level of the center channel as much as 10dB. The proper setting for this control will vary depending on the recording and your taste. There is no "correct" setting.

HIGH PASS removes low frequencies from the center, side and rear outputs. This is particularly useful if you will be using the Full Range mode at high volume levels where the low frequencies might damage the smaller speakers.

SUB BASS BOOST boosts or cuts the subwoofer output level. Although the normal subwoofer level was set during the initial calibration procedure, with some recordings you may find it desirable to increase or decrease this deep bass level.

In Full Range, **MAIN MUTE** mutes the front outputs if the system is configured with side speakers, otherwise it is inactive; **EFFECTS MUTE** mutes the center, sides (if configured) and the rear outputs.

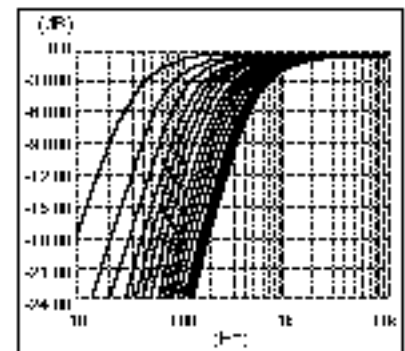

High Pass Filter
The high pass filter attenuates low frequencies at 9dB per octave. The values given are for the -3dB point.

Mono Logic

Parameter	Initial Value	Range
TREBLE ROLLOFF	2.5 kHz	125 Hz - 100 kHz
ACADEMY FILTER	000	000-007
MAIN LEVEL	0015*	0-15

* 6 if configured with center speaker;
15 if configured without center speaker (Presets only)

The setting of EFFECT LEVEL is very important in Mono Logic. If this control is set too high, the sound will be too reverberant; too low, a setting will result in an insufficient amount of the effect. This control adjusts the loudness of the side and rear outputs as well as the amount of ambient signal mixed into the front speakers.

TREBLE ROLLOFF regulates the treble cut in the side and rear channels. The optimal setting for this parameter will vary widely with the age, quality and condition of the source material.

ACADEMY FILTER is provided to recreate the proper tonal balance of older monaural films, which were recorded with a much narrower and duller frequency response than current films.

MAIN LEVEL controls the level of the mono signal which is reproduced by the main speakers. When there is a center speaker configured, many films may sound better when this control is set between 6-12. This will spread the film sound out around the screen and can be more pleasant than restricting the dialog and much of the other film sound to the center speaker.

In Mono Logic, MAIN MUTE mutes the center output; EFFECTS MUTE mutes the front, side and rear outputs.

Pro Logic

Parameter	Initial Value	Range
AUTO AZIMUTH	ON	Off/On
BASS SPLIT	REAR**/FRONT*	REAR**/FRONT*
SUB BASS BOOST	THX	THX/FRONT/REAR
SIDE SPEAKER ASSIGN**	REAR	FRONT/FRONT

* depends on speaker configuration

** Inaccessible if side speakers configured as THX or NONE

EFFECT LEVEL controls the loudness of the front, side and rear outputs.

The AUTO AZIMUTH/BAL (short for Auto Azimuth Error Correction/Automatic Input Balance) parameter should be set to ON for films, OFF for music. When it is on, special patented algorithms continually monitor the input signal and adjust both the relative level and time offset of the two channels to keep the dialog properly centered and special effects properly localized. This automatic feature is why the CP-3 does not have or need an input balance control for Dolby Surround decoding.

BASS SPLIT takes the low bass from the center, where it is in many film and music mixes, and distributes it instead to the left and right front-channel speakers. Bass Splitting is valuable because in many video installations the center speaker is smaller than the two main stereo speakers and is less capable of handling the lowest frequencies. By directing the low frequencies to the main speakers, there is less risk of damage to a small center speaker and no loss of bass information since it will be reproduced by the main speakers.

SUB BASS BOOST boosts or cuts the subwoofer output level. Although the normal subwoofer level was set during the initial calibration procedure, with some recordings you may find it desirable to increase or decrease this deep bass level.

SIDE SPEAKER ASSIGN determines whether the information fed to the side outputs is derived from the front left and right, or from the rear. Choosing the front setting will create a very wide soundstage, which can be very exciting on some soundtracks. On others, particularly those with panned dialog and very tight localization of sound effects, the soundstage will be too wide. Technically, the rear setting is a closer match to the original recording format.

In Pro Logic, MAIN MUTE mutes the center output; EFFECTS MUTE mutes the front, side and rear outputs.

THX Cinema

Parameter	Initial Value	Range
RE-EQUALIZER	ON	ON/OFF
AUTO AZIMUTH	ON	ON/OFF
BASS SPLIT	Depends on Eq. *	Depends on 120 Hz
SUB BASS BOOST	0dB	-05dB to +15dB

* depends on speaker configuration

EFFECT LEVEL is inactive in this mode.

The RE-EQUALIZER equalizes the left, center and right channel outputs to match the overall frequency balance of the original recording. Without this re-equalization, many films, and some television programs, will sound too bright and become fatiguing to listen to.

The AUTO AZIMUTH/BAL (short for Auto Azimuth Error Correction/Automatic Input Balance) parameter should be set to ON for films, OFF for music. When it is on, special patented algorithms continually monitor the input signal and adjust both the relative level and time offset of the two channels to keep the dialog properly centered and special effects properly localized. This automatic feature is why the CP-3 does not have or need an input balance control for Dolby Surround decoding.

BASS SPLIT takes the low bass from the center, where it is in many film and music mixes, and distributes it instead to the left and right front-channel speakers. Bass Splitting is valuable because in many video installations the center speaker is smaller than the two main stereo speakers and is less capable of handling the lowest frequencies. By directing the low frequencies to the main speakers, there is less risk of damage to a small center speaker and no loss of bass information since it will be reproduced by the main speakers.

SUB BASS BOOST boosts or cuts the subwoofer output level. Although the normal subwoofer level was set during the initial calibration procedure, with some recordings you may find it desirable to increase or decrease this deep bass level.

In THX, MAIN MUTE mutes the center output; EFFECTS MUTE mutes the front, side and rear outputs.

If you encounter a problem, please review the items in the following checklist. Also be sure to thoroughly check all other connected components such as speakers, receiver/amplifier/preamp, VCR, TV, CD player, etc.

Troubleshooting

Problem	Possible Cause and Solution
Power does not come on	Check line cord to ensure good connection to the AC outlet and to the receptacle on the CP-3 rear panel. Check to make sure that the CP-3 rear panel power switch is ON.
Input level meters not functioning	Check to make sure that "LEVEL METERS" (in the DISPLAY ADJUST sub menu of the Setup menu) is turned ON. Make sure CP-3 VOLUME is above -54dB. Make sure that the correct input is selected.
No audio	Check input and output connections. They may be reversed relative to the IN and OUT jacks of your receiver/amplifier/preamp or other source.
Remote control not working	Check batteries to be certain that they are inserted correctly with proper polarity. Make sure that the infrared sensor on the CP-3 front panel is not obstructed. Try using the other remote. If neither is working, the problem is internal. See "If all else fails..." on the following page.
"Wrong remote" message	The CP-3 recalls which remote (Standard or Expanded) was last used to turn it on. Turn the CP-3 off, then back on with the remote you wish to use.
No output	Make sure that signal is coming into the CP-3 by observing the Input Level meters. Increase VOLUME using the remote control and check Front/Back and Left/Right BALANCE. Check the CP-3 MUTE controls to make sure they are not engaged. Check all other equipment settings and connections and verify that the amplifiers being fed by the CP-3 are operational. Remember that the CP-3 mutes the output to any speakers which are not configured in the Setup menu. If speakers are added to (or removed from) your system, the Speaker Configuration menu must be altered accordingly.
Center Channel only plays	Check to see if your HiFi VCR has dropped out of tracking — readjust. Your VCR Stereo/Mono/L-R switch may be in the wrong position — set it to Stereo.
Muffled sound in L&R channels	When no center channel is used, CENTER must be configured for NONE in the Configuration menu.
Center channel sound muffled	The center channel amp may be connected to the subwoofer jack on the CP-3 rear panel. Reconnect to Center Output jack.

Problem	Possible Cause and Solution
Hum	<p>Finding and eliminating audio hum in a complex installation can be a very frustrating task. Often, the easiest way to identify the culprit(s) is to systematically eliminate devices from the audio chain. If Cable TV is connected to any component in the system, start by unplugging the Cable completely, preferably right at the wall jack. If this eliminates, or greatly reduces the hum, it is worth a call to your Cable company. A quick fix, assuming your cable is round 75Ω wire, is to attach a 75-300Ω transformer to the end, then attach a 300-75Ω transformer to that, so that the end is back to a round 75Ω wire. There are commercially-available antenna lead isolators which may provide additional insulation from electrical surges.</p>
Clicking in audio	<p>In some systems a very slight clicking may be audible with sources that are at a consistently low level. This is an artifact of the CP-3's S/N Optimization system. To prevent this, the S/N Optimizer for each input this is observed on should be turned OFF, although defeating it will result in an increase in background noise. As always, be sure to set the input level as high as possible.</p>
Interference with AM, FM,TV or Cable TV	<p>The CP-3 does generate minimal amounts of RF energy and is in compliance with FCC rules. If some interfering noise is noted, move AM loop and FM "T" type antennas away from the CP-3 and reorient them as necessary. Use shielded cable for FM and TV antenna feeds.</p>
Erratic recall of modes	<p>Severe power surges or sags can confuse the CP-3 memory. To correct, or if you simply want to start over, restore the factory defaults with the procedure described at the end of this section.</p>
Rear speaker off in THX mode	<p>See note on side speakers, page 21.</p>
If all else fails...	<p>Turn off all amplifiers. Turn the master power switch on the CP-3 rear panel OFF, wait 10 seconds, then turn it ON again. This causes the unit to run a diagnostic self-test routine which takes a couple of seconds. If the CP-3 LCD displays normally at the end of this test, no problems have been found with the CP-3 circuitry. If the internal tests fail, the LCD may display an error message, or no message at all. If this happens, contact Lexicon.</p> <p>If you find that when the rear-panel master POWER switch is turned ON, the CP-3 routinely displays the message "INITIALIZING", or if you find that User settings are being replaced with factory defaults after power OFF, the lithium battery in the CP-3 may be faulty. This part is not field-replaceable, contact Lexicon.</p> <p>If the unit is still behaving erratically, perform the Restore Defaults procedure described on the following page.</p>

Other than occasional replacement of the batteries in the remote control units, the CP-3 requires minimal maintenance. Use a soft, lint-free cloth slightly dampened with warm water and a mild detergent to clean the exterior surfaces of the unit.

**Do not use alcohol, benzene or acetone-based cleaners
or any strong commercial cleaners.**

Avoid using any abrasive materials such as steel wool or metal polish. If the unit is exposed to a dusty environment, a vacuum or *low-pressure* blower may be used to remove dust from the CP-3 exterior.

If severe power surges or sags cause problems with CP-3 memory storage, or you simply want to start with a clean slate, you can restore factory presets into the User registers with the following procedure.

**This will erase any programs you have stored in the User registers,
as well as all setup and calibration values.**

Note any settings you want to re-use before proceeding.

With the Expanded Remote control, turn the CP-3 OFF. Turn the unit back ON and press the SETUP button within two seconds. (Make sure you do not block the infrared receiver on the CP-3 front panel.) Continue holding down SETUP until the display reads:

* RESTORE MODE *
SETUP TO EXIT

(If you want to resume normal operation *without* restoring all defaults, this is your last chance. Release SETUP and press SETUP again to resume normal operation.)

To restore defaults, release SETUP and press STORE to clear and reload User registers, and to restore all factory settings of Volume, Balance, Contrast, Configuration, etc.

The display will flash an INITIALIZING message then read:

* RESTORED ALL *
SETUP TO EXIT

Press SETUP to resume normal operation.

All of the adjustable parameters in the CP-3 have now been reset to the values assigned when it cleared final Quality Control at the factory. Using the values notated on the Installation Worksheet at the end of this manual, follow the initial setup procedure starting on Page 18.

If you cannot solve functional problems through these procedures, consult your dealer or Lexicon/Customer Service Department.

<p>DO NOT, UNDER ANY CIRCUMSTANCES, OPEN THE UNIT. DOING SO WILL VOID YOUR WARRANTY, AND MODIFICATIONS MAY RENDER THE UNIT UNSERVICEABLE.</p>
--

Routine Maintenance

Restoring Defaults

**Installation
Documentation**

This section is provided for the documentation of values set during system setup and calibration. The Setup menu selections are reproduced here for your convenience when filling out the worksheet.

The Setup Menu

Move cursor with
PARAM then press PARAM ▲ or ▼ to select

SETUP MENU
→ INPUTS
DISPLAY ADJUST
SPEAKER CONFIG
OUTPUT LEVELS
LISTENER POS
LOCK SETTINGS
SETUP TO EXIT

Press SETUP to display the Setup menu. PARAM will step the cursor through the Setup menu selections. Once an item is selected, pressing PARAM ▲ or ▼ will display a sub-menu for that item. With the sub-menu displayed, PARAM once again selects menu items. PARAM ▲ and ▼ adjust the settings of the selected item over its available range. Press STORE to exit any sub-menu; press SETUP to return to the Setup menu. Press SETUP again to exit the Setup menu. For your reference, all of the options available in the Setup menu are shown here.

Move cursor with
PARAM then press PARAM ▲ or ▼ to select

INPUT MENU	Adjust with PARAM ▲ or ▼
SET INPUT GAIN	-18dB to +12dB
SET INPUT NAME	16 characters available
AUTO MODE LOAD	OFF, F1-15, A1-15, B1-15
AUTO LEVEL	ON or OFF
SN OPTIMIZER	ON or OFF

*A# refers to the currently selected input. Pressing any of the INPUT buttons will select that input for adjustment.

DISPLAY ADJUST	Adjust with PARAM ▲ or ▼
OSD POSITION	Bottom, Center, Top
DISPLAY TIME	Always Off, 2 sec. timeout, Always On
LCD CONTRAST	continuously adjustable
LEVEL METERS	ON or OFF

CONFIG MENU	Adjust with PARAM ▲ or ▼
80HZ HPF	ON* OFF
CENTER	FULL* SMALL NONE
SIDES	THX* STANDARD NONE
REARS	TWO* ONE NONE
SUBWFS	YES* NO

*factory default settings:

OUTPUT MENU	Adjust with PARAM ▲ or ▼												
INTERNAL SOURCE	<table border="0"> <tr><td>LEVEL MENU</td><td></td></tr> <tr><td>L. FRONT</td><td rowspan="7">-18dB to +6dB</td></tr> <tr><td>CENTER*</td><td rowspan="7">*Not selectable if "NONE" selected in Config Menu.</td></tr> <tr><td>R. FRONT</td></tr> <tr><td>R. SIDE*</td></tr> <tr><td>L. SIDE*</td></tr> <tr><td>SUBWFS*</td></tr> <tr><td>R. REAR*</td></tr> <tr><td>L. REAR*</td></tr> </table>	LEVEL MENU		L. FRONT	-18dB to +6dB	CENTER*	*Not selectable if "NONE" selected in Config Menu.	R. FRONT	R. SIDE*	L. SIDE*	SUBWFS*	R. REAR*	L. REAR*
LEVEL MENU													
L. FRONT		-18dB to +6dB											
CENTER*			*Not selectable if "NONE" selected in Config Menu.										
R. FRONT													
R. SIDE*													
L. SIDE*													
SUBWFS*													
R. REAR*													
L. REAR*													
EXTERNAL SOURCE													

LISTENER POS	Select with PARAM	Adjust with PARAM ▲ or ▼
PANORAMA CALIB	Calibrate Noise	Off, Left Only, Right Only, Left & Right
	Spkr/ Lstr Ang°	29° - 90°
	Listener Pos	L127...Center...R127
REAR DELAY	15-30msec	

SETTING MENU	Adjust with PARAM ▲ or ▼
SETTING LOCK	ON or OFF
CUSTOM NAME	See Manual

Installation Worksheet

CP-3 serial # _____

Installed by _____ Phone _____ Date _____

Input	Gain	Name	Auto Mode Load	Wiring comments
1	____ dB	_____	_____	_____
2	____ dB	_____	_____	_____
3	____ dB	_____	_____	_____
4	____ dB	_____	_____	_____

- OSD Position** bottom center top
- Display Time** always on 2 sec. time out always off
- Level Meters** on off

Amp Gain settings _____

Speaker Configuration [circle selection)

80Hz HPF	ON	OFF	
Center	FULL	SMALL	NONE
Sides	THX	STANDARD	NONE
Rears	TWO	ONE	NONE
Subwoofers	YES	NO	

Listener Position

Speaker Listener Angle _____°
 Listener Position _____
 Rear Delay _____ milliseconds

Output Levels

	Wiring comments		Wiring comments
Left Front _____ dB	_____	Left Side _____ dB	_____
Center _____ dB	_____	Subwoofer _____ dB	_____
Right Front _____ dB	_____	Right Rear _____ dB	_____
Right Side _____ dB	_____	Left Rear _____ dB	_____

AC Power wiring notes

Specifications

- Inputs:** Audio: 4 stereo pairs
Minimum Input Level: 300 mVrms for maximum output
35 mVrms for Dolby level
Input Impedance: 100 k Ω in parallel with 100pf
- Video: 3 composite, NTSC M standard
Input Sensitivity and Impedance: 1V p-p, 75 Ω
- Outputs:** Audio: 8 outputs (Left, Right, Center, Subwoofer, 2 Side, 2 Rear)
Maximum Output Level: 6 Vrms
Output Impedance: 500 Ω
- Video: 1 composite, NTSC M standard
Output Level and Impedance: 1V p-p, 75 Ω
- Frequency Response:** Unprocessed channels: 10 Hz - 100 kHz, +1, -3dB, Ref. 1 kHz
Processed channels: 10 Hz - 18 kHz, +1, -3dB, Ref. 1 kHz
- Subwoofer: 10 Hz-80 Hz, +1, -6dB, Ref. 31.5Hz, 24dB/octave rolloff
- THD:** All channels: Less than .025% @1 kHz, max level
Subwoofer: Less than .025% @10-100 Hz, max level
- Signal to Noise Ratio:** 90dB minimum, A-weighted, Ref. 1 kHz max level
- Power Requirements:** 120 VAC \pm 10% 50-60 Hz 35W
100/220/240 VAC versions available
3-pin IEC detachable power cord provided
- Dimensions:** 17.5"W x 14.5"D x 3.7"H (445 x 368 x 94mm)
Brackets supplied for rack mounting: conforms to 19" standard, 2U high
(3.5"H without feet)
- Weight:** 18 lbs. 4oz. (8.3kg)
- Environment:** Operating Temperature: 32° to 95°F (0° to 35°C)
Storage Temperature: -22° to 167°F (-30° to 75°)
Humidity: 95% maximum without condensation
- Remote Controls:** 2 hand-held, battery-powered remote control units provided
with each CP-3; each uses 2 AA batteries (provided):
1 18-button "Standard" remote
1 36-button "Expanded" remote

Specifications subject to change without notice.



Lexicon, Inc.
3 Oak Park
Bedford, MA 01730
Tel 781-280-0300
Fax 781-280-0490